

HYDRA POOLS

Installation Manual

Instructions for:

Pool Location

Excavating

Grading

Plumbing and Drains

Pool Walls and Ladders

Back Filling

Decks

Lighting

Steps

Coping

Skimmers

Pool Covers

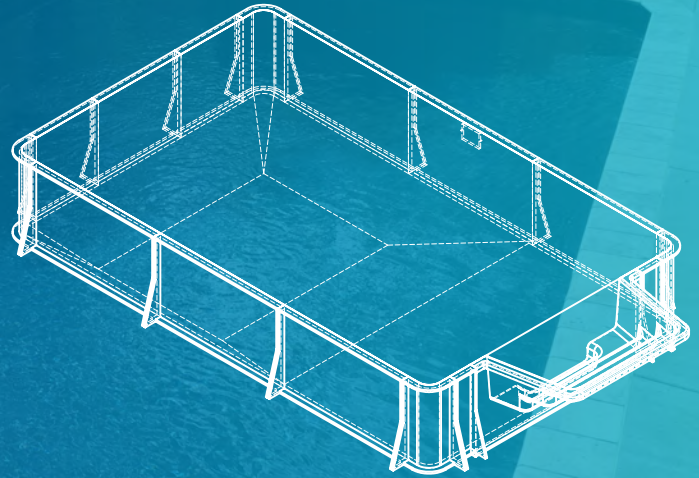



Table of Contents

General Guidelines..... Page 3
Tools & Equipment..... Page 3
Warnings..... Page 4
Location/Layouts..... Page 6
Excavation..... Page 7
Panel Installation..... Page 10
Step Installation..... Page 12
Leveling..... Page 13
Main Drains..... Page 14
Return Fittings..... Page 14
Coping..... Page 15
Skimmers..... Page 16
Lights..... Page 16
Perimeter Collar..... Page 17
Sono Tubes..... Page 17
Prepping Bottom..... Page 18
Liner Installation..... Page 19
Backfilling..... Page 21
Concrete Deck..... Page 22
Detail Drawings..... Page 22
FAQs..... Page 27
Aqua Genie..... Page 33
Pool Cover..... Page 41

For A Copy of
**Standards for Residential
Swimming Pools**

Contact the:
APSP
2111 Eisenhower Ave.
Alexandria, VA 22314
(703) 838-0083
(703) 549-0493

IMPORTANT NOTICE

The installation of an in-ground swimming pool is a complicated construction project. The owner’s manual accompanying your Hydra Pool kit contains general information regarding the correct installation and assembly of your pool. The incorrect installation and assembly of your pool, including but not limited to incorrect excavation and site preparation, will impair the life span of your pool, cause your pool to leak, and also void your Hydra Pool warranty. Hydra Pools does not recommend you self-install and assemble your pool. Hydra Pools recommends that only a competent professional such as a contractor of good standing, licensed and insured to perform this work in your area, be utilized to install and assemble your pool. Further, installation of a swimming pool may require you to obtain advanced permitting and/or approval of local government agencies as well as compliance with applicable regulations, if any, such as perimeter fencing for your property.

GENERAL GUIDELINES

Before you begin, check the pool component list and read the entire installation manual. During the various steps of installation, refer to this installation manual, the installation video and the appropriate “dig specs” drawing supplied to you. As always check any state or local buildings codes before proceeding

Construction Sequence

1. Check with utility company in regards to underground utilities (gas, electric, phone, etc.). In many states there is a toll free number you must call prior to digging.
2. Obtain all necessary permits.
3. Hire an electrician if needed. Check all local and national codes.
4. Arrange for water to be delivered if necessary.
5. Arrange for fencing around the pool area and check local codes for requirements.
6. Follow this installation manual carefully and complete only the steps that pertain to the pool you are installing.

Tools Needed for Installation

Adjustable Wrench
Screwdrivers
Socket Set
25' and 100' Tape Measure
Utility Knife
Extension Cords
String Line
Drills and Assorted Bits
Shovels (flat and round)
Trowel (pool trowel 14")
Carpenter's Square
Levels - 4ft and 6ft
Wheelbarrow
3" Hole Saw
Hacksaw
2" Hole Saw
Large Channel-Lock Pliers
Broom
Tamper

Sledge Hammer/Regular Hammer
Hose
Duct Tape
Transit (laser level preferred) (rent)
Rakes
Commercial Shop Vac /blower (2HP 130 CFM recommended)
Pick Axe
Caulk Gun
Cement Mixer/Plaster Mixer (needed for installation of vermiculite bottom—rent if necessary)
Spray Paint (for marking ground)
Leather Gloves
Grade Stakes
Pipe Cutter
Hacksaw/Bandsaw (for coping)
Teflon Tape
Silicone RTV

Heavy Equipment Needed (hire if necessary)

Backhoe or Mini-Excavator
Bobcat
Dump truck

Note: A qualified operator is needed for heavy equipment.

Electrical

Hire a licensed electrician to complete all electrical bonding & grounding requirements.

Installation must be performed in accordance with Local and NEC codes.

SAFETY WARNINGS

Basic safety precautions should always be followed, including the following: Failure to follow instructions can cause severe injury and/or death. **SERIOUS INJURY OR DEATH CAN RESULT FROM THE IMPROPER INSTALLATION OR USE OF THIS POOL.**



WARNING - Before You Dig - Call 811! 811 is the phone number you call before digging to protect yourself and others from unintentionally hitting underground utility lines.



WARNING - Risk of Electric Shock. All electrical wiring MUST be in conformance with applicable local codes, regulations, and the National Electric Code (NEC). Hazardous voltage can shock, burn, and cause death or serious property damage.

NOTICE - A licensed electrician must do all wiring.



WARNING - Risk of Electric Shock. Failure to ground all electrical equipment can cause serious or fatal electrical shock hazard. Electrical ground all electrical equipment before connecting to electrical power supply.



WARNING - Risk of Electric Shock. Failure to bond all electrical equipment to pool structure will increase risk for electrocution and could result in injury or death. To reduce the risk of electric shock, see installation instructions and consult a professional electrician on how to bond all electrical equipment. Also, contact a licensed electrician for information on local electrical codes for bonding requirements.

Notes to electrician: Use a solid copper conductor, size 8 or larger. Run a continuous wire from external bonding lug to reinforcing rod or mesh. Connect a No. 8 AWG (8.4 mm²) [No. 6 AWG (13.3 mm²) for Canada] solid copper bonding wire to the pressure wire connector provided on the electrical equipment and to all metal parts of swimming pool, spa, or hot tub, and metal piping (except gas piping), and conduit within 5 ft. (1.5 m) of inside walls of swimming pool, spa, or hot tub. **IMPORTANT - Reference NEC codes for all wiring standards including, but not limited to, grounding, bonding and other general wiring procedures.**



IMPORTANT INSTALLATION INFORMATION: Installation should be done strictly in conformance with all local building codes, electrical codes and other building and safety laws and regulations. Among other things, that your installer should carefully analyze the need to bond the product to prevent an electrical hazard. Failure to properly install this product could result in a dangerous condition, including but not limited to electrical or structural hazards. Hydra Pools disclaims all liability arising from the installation and the user assumes all risk associated with the installation.



WARNING - Make sure to install the safety rope anchor devices and the rope and float assembly.



WARNING - DO NOT DIVE OR JUMP UNLESS YOUR POOL IS A DIVING POOL. IF YOU DIVE OR JUMP INTO YOUR POOL YOU RUN THE RISK OF PERMANENT INJURY OR DEATH. Enclosed in the liner box is the safety envelope. The safety stickers must be installed as per instructions. Failure to properly install warning labels will void warranty. Alert all visitors and family of the risks associated with jumping and/or diving and point out all warning labels supplied. Failure to mount these safety labels may subject you to substantial liability in case of injury.

**WARNING**

1. Everyone who uses this pool must know, understand and follow these instructions
2. This pool is designed for residential in ground pool use only. This pool may not be used as a above ground or semi-above ground pool.
3. Be familiar with the shape and depth of the pool before entering the pool.
4. Take caution not to wear any objects or jewelry that may puncture your pool liner.
5. If your pool is a Non-Diving Pool clearly mark it as such. Post stickers and signs to prevent diving. Failure to do so can cause serious injury or death.
6. No roughhousing or horseplay should be allowed in the pool at any time.
7. Do not use this pool if physically impaired or handicapped without your doctor's permission.
8. Do not use this pool with a history of heart conditions, seizures, back problems, or fainting.
9. Persons taking medications, which induce drowsiness, such as tranquilizers, antihistamines or anti-coagulants, should not use this pool.
10. Drinking of alcoholic beverages before or during pool use can cause drowsiness, which could lead to unconsciousness and subsequently result in drowning.
11. Do not drink alcohol and use this pool.
12. Do not use pool if bottom is not clearly visible. At night, sufficient lighting must be available. It is the pool owners' sole responsibility to provide adequate lighting for the pool bottom, safety signs and walkways, which exceeds minimum standards of the IES of North America.
13. Be sure that all toys, chairs and tables or similar objects that a young child could climb on be at least 4' from the pool.
14. Do not use pool during electrical or rain storms.
15. Provide fencing or an enclosure which is independent of the house as a closure around the entire pool area. The fencing must be made of durable material, check local codes for minimum height requirements, only use closures with self-latching locks to make the pool inaccessible to toddlers and uninvit-

POOL LOCATION/LAYOUT

Location:

1. Review the local building codes for setback, easements, variances and utilities (call utility companies).
2. Look for flat, drainage away from pool is needed, a clear area will also help reduce costs.
3. Have a wide access area for excavation equipment.
4. Look for a sunny area, with little to no trees.
5. Look at prevailing winds for skimmer and return locations.
6. Position pool to be near rest rooms.
7. Position pool to be close to electrical supply to help reduce costs.
8. Make sure the pool will not be built on fill dirt.

RECTANGLE POOL:

When laying out pool please be advised that the excavation will have an “over dig”. The over dig is typically 30” larger than the pool on each side and will enable you to work on the back side of the pool with ample room to spare. The over dig is an extension of the shelf. The shelf is where the panels rest. Note: the over dig may vary based on pool walls and braces combinations. Over dig is typically 24” to 36” greater than the pool size.

Examples: A 14’ x 28’ rectangle pool will have an excavation of 19” x 33”
 A 16’ x 32’ rectangle pool will have an excavation of 21” x 37”
 A 18’ x 36’ rectangle pool will have an excavation of 23” x 41”

NOTE: Always square the dig layout. If the pool has a step, take the position of the step and add extra excavation area for the steps. Drive stakes in the ground to form the box, use a bright marker paint to show the lines of the pool on the ground.

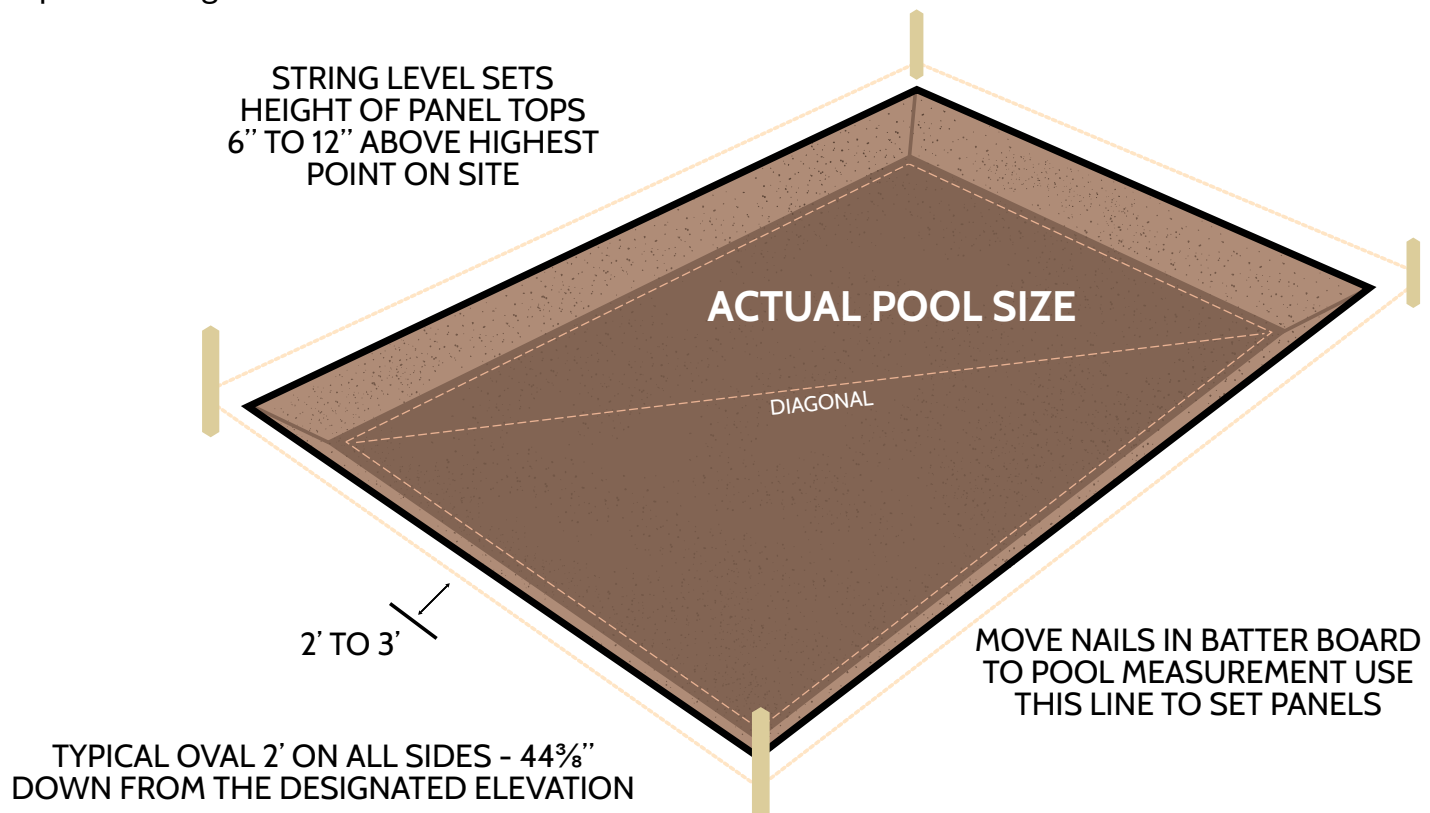

RADIUS POOLS AND OVAL SHAPE LAYOUTS

- There are many ways to layout radius pools. One of the easiest is to form a box of the maximum length and width of the pool and place a stake at the four points.
- Using two long tape measures you can triangulate the center points of the radius. You must have large space to “swing.”
- Then drive a stake at the radius center point and swing the arcs. You can initially use baking flour to mark ground so it may be easily changed prior to using the more permanent marker paint.

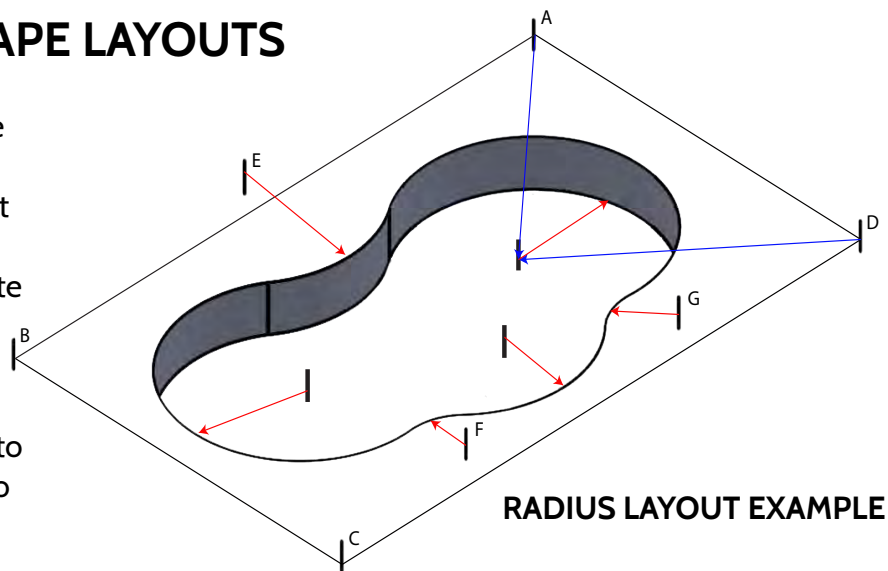

NOTE: Always check dimensions prior to starting excavation.

STEPS:

If the pool will have a step, add area to the layout to allow for it. Steps vary in size and shape. An 8' wide straight step is typically 4' deep so you will need to over dig 24" around the step, or a 12' wide by 6' deep over dig.

ELEVATION:

Elevation is a very important part of the pool layout. The pool should be 6-12" higher than the existing grade. You want drainage away from the pool but you also do not want drainage towards the house or other critical areas.

- The elevation of the pool will include the pool wall height and any copings that will be used on the pool. A 42" or 48" high pool wall with a 2 ³/₈" coping will have a height of 50 ³/₈" total height.
- When proper elevation is determined, place string lines to the layout stakes. This will enable you to have a consistent reference point (benchmark) when using your laser level or transit.

Note: You should reference an existing point on a house, deck or walkway to determine the elevation.

EXCAVATION (AKA THE DIG) - CALL BEFORE YOU DIG FOR UTILITIES

Note: Your yard will become a building site at this point and you will have a big hole in the ground with piles of dirt in the yard.

- Confirm all the dimensions that have been used for layout.
- Confirm that you have contacted all necessary companies for obstructions and utilities. Also make sure local building codes have been met prior to excavation.
- Review ALL manufacturer layouts and dig specifications.
- Excavation will always be 2" deeper than manufacturers layout sheets; the extra 2" is for installation of the pool base material.

THE SHELF

The Shelf is the part of the excavation that you will place the panels and braces on and it will be the point at which the initial elevation is determined. The shelf is excavated to the wall height and coping height from the string line or benchmark point. NOTE: The shelf must be on undisturbed soil.

- Do not dig the shelf deeper than needed.
- The shelf point is also the excavation depth for shallow end; you will have 2" of base material before liner installation.

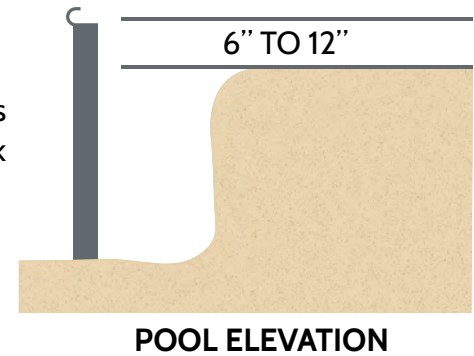

EXCAVATION (continued)

There are many ways to excavate a pool and the excavation may vary on machinery, area and operator preference.

NOTE: It is best to have a few people to aid in the excavation. One person can assist operator with depth and shape of the pool dig. Also, use marker paint to highlight slopes and transition lines for the operator. The better the excavation the less work you have later!

SHALLOW END:

- Use the benchmark or the string line as a guide for the shallow end depth. The bottom of the dig will be the start of the shelf.
- When the shallow end is completed, mark the transition line or line from shallow to deeper. Also, drive stakes at the transition point at the correct width of pool. These stakes will be later used to "string" the bottom for final dimensions.

HOPPER or DEEP END

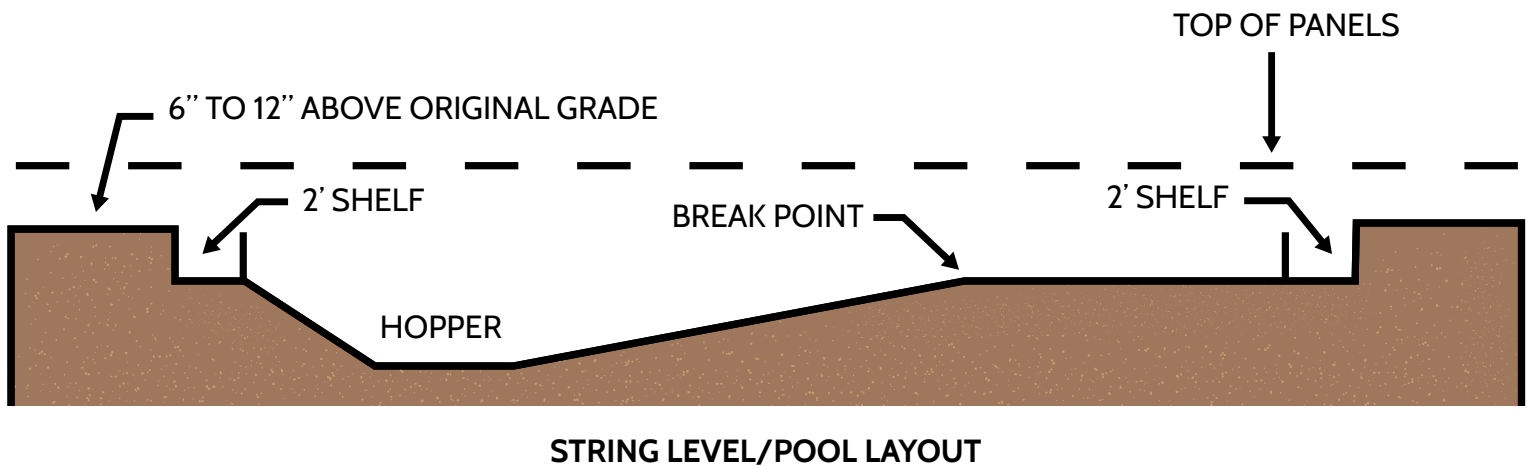

NOTE: The excavated depth will be 2” deeper than the finished depth. You will have 2” of base material on excavated soil.

- Draw out the hopper or deep end area with marker paint; this will assist the excavator with the dig. Having someone inside the pool area working with the excavator would be a great help, but that person must be careful!
- A typical slope for a diving pool is 14’ long. The length is measured from the shallow end transition line to the transition line at the beginning of the flat deep end.
NOTE: A pool that has a 14’ slope becomes narrower as it is dug towards the bottom of the pool. For every 42” or 3’6” of slope length, the slope becomes 12” or 1’ deeper on each side.

In Example: a 16’ wide pool will have a slope width of 16’ at the shallow end transition line. If you measure down the slope 3’ 6” that width of the slope will be 14’ wide. At the half way mark (or 7’) down from the shallow end transition line, the width would be 12’ etc.

- Mark the flat hopper bottom with marker paint, refers to the dig specifications provided by the liner manufacturer for this information. Have the operator dig the hopper.
- After the hopper is complete, begin to excavate the sides and back slopes in accordance with the liner manufacturer’s specs. The liner manufacturer specs will be two inches less than excavated specs.
- When the pool is completely excavated, drive stakes at all transition points.

The stakes will be used for two reasons, one being the position of the walls during the wall assembly process. The stakes will also enable you to “string” the bottom of the pool for the base material installation.

Refer to Actual Dig Specification For Pool Installation

NOTE: The proper layout is important in that the skimmers and returns should be in the correct position in order to have proper circulation. The skimmer should be in line with the prevailing wind and the returns should be positioned so that movement of the debris on the surface is towards the skimmers. The skimmers, returns and lights are typically precut. General rule of thumb; one skimmer per 400 square feet of surface area.

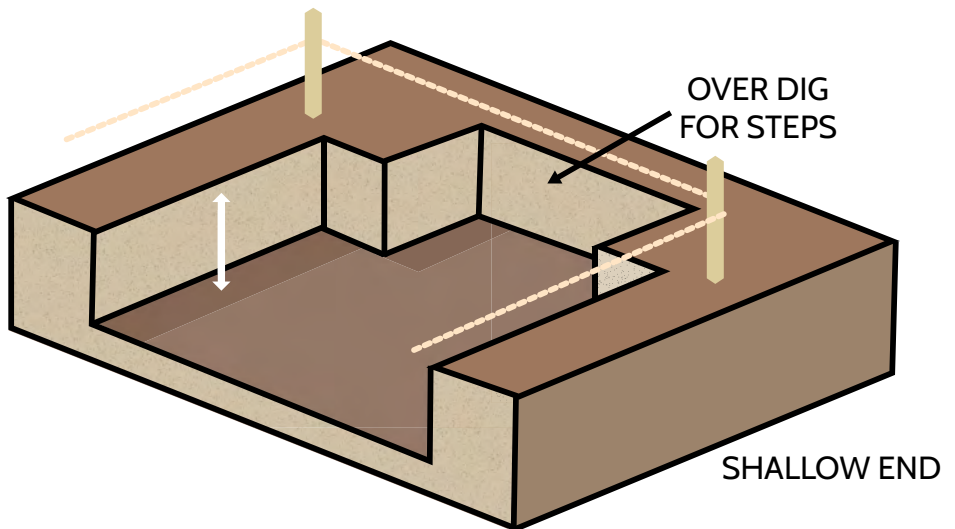

2' TO 3' SHELF ON ALL SIDES OF PERIMETER

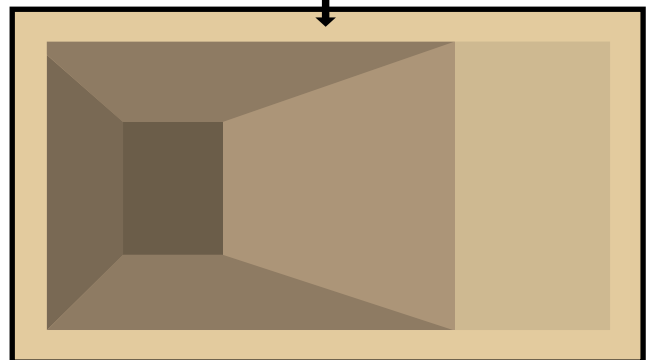

SHALLOW END

GROUND-WATER CONDITIONS

Ground water is the term used for the water table. If you should encounter ground water while digging the hopper, don't panic. Just follow these simple recommendations:

1. Over dig just the bottom of the hopper by 1' to 2'.
2. Use pea-sized rock to bring the hopper back to grade.
3. Set sump pump in the pea stone and plumb it to outside of the pool.
4. Run a plumbing line from the hopper to near the filter.
5. Pump to area away from pool and keep the pump running continuously until the liner has been dropped and the pool is full of water.
6. When installation is complete, unplug the pump, leaving it available for use in the future, should the liner need to be replaced.

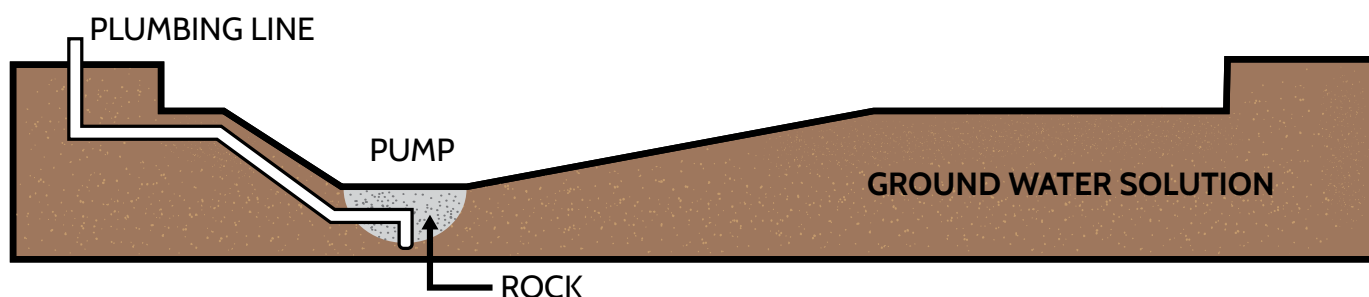

PANEL INSTALLATION

Note: For safety, wear gloves when handling steel panels and components. Start by laying out all panels on the panel shelf. Position a brace and necessary bolts (depending on the brand of panel) at every panel joint, as indicated in the Pool Layout and Dig Dimension Drawing supplied to you.

Starting in the appropriate place for the shape of the pool being built, fasten panels and braces together using the supplied bolts. Align the panel joints for a tight fit and hand-tighten (snug) the supplied non-corrosive bolts. **DO NOT OVER-TIGHTEN!**

Panels are available with precut holes for most commonly used skimmers. Position the skimmer panel according to the following guidelines:

1. Locate the skimmer as per supplied drawing.
2. Insure the skimmer panel will be clear of the wall-mounted safety-rope anchors.
3. Locate returns on walls around the pool to push surface debris in a circular motion towards the skimmer.
4. Aqua Genies do not require additional returns, see the Aqua Genie Manual.

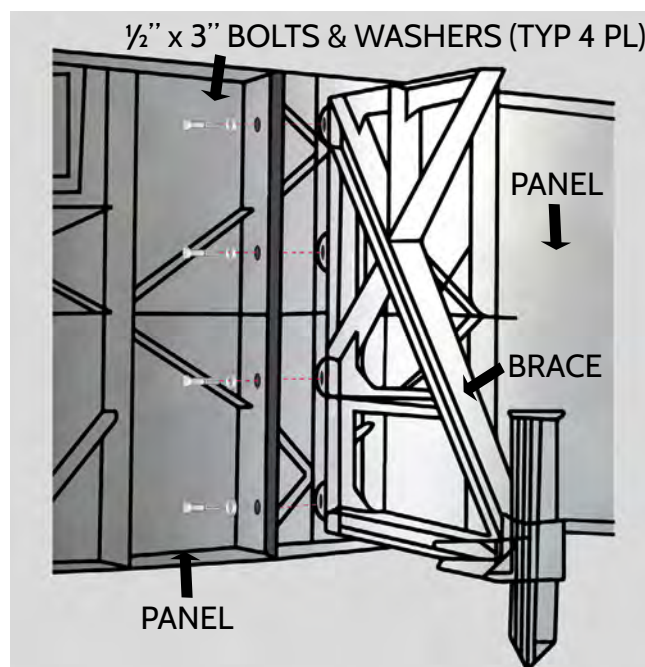

BASIC BRACE INSTALLATION ON POLYMER

5 ° WEDGE

The 5 ° wedge is used to change the radius of the pre-molded polymer panel. Loosely fit the brace to the panels and slide the wedge between the brace and the bolt. You will tighten the bolts later, after the full radius is set.

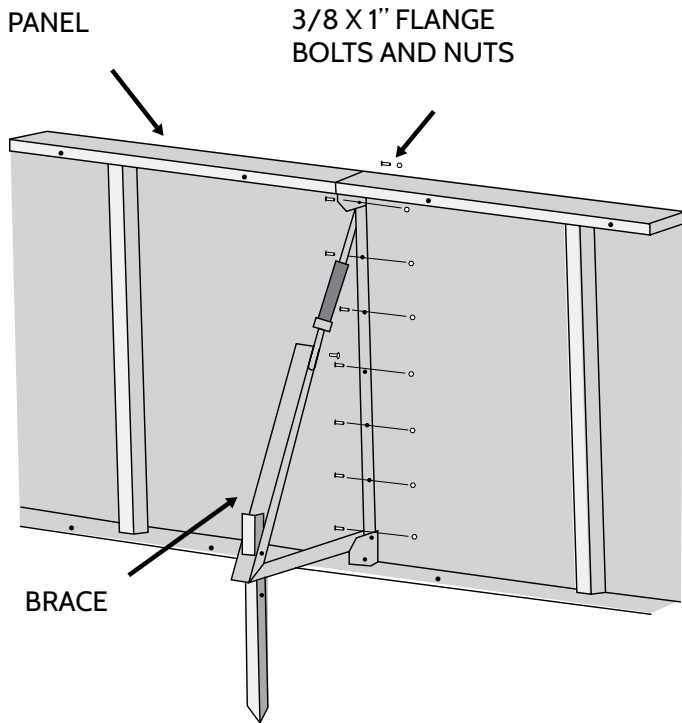
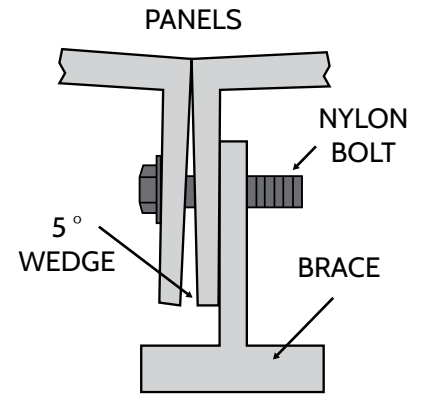

BASIC BRACE INSTALLATION ON STEEL

TYPES OF STEEL PANEL BRACES



TYPES OF POLYMER PANEL BRACES



STEP INSTALLATION

- Start at the step area. Place the step in the area in which the excavator dug the step area. Have steps self supported at that point.
- You can attach a panel to each side of the step with “C” clamps, do not permanently attach it at this point.
- Install next panel to one of the panels temporarily attached to step. Use the fasteners provided with the pool walls. (Polymer and Steel Walls use different types of fasteners.) Steel nuts and bolts, nylon nuts or bolts and wedge systems are the most common.
- Attach brace at each panel joint, as well as the joint where the pool wall meets the step. **DO NOT TIGHTEN.**

NOTE: do not drive any brace stakes at this point

- For radius pools, use the manufactures dig specifications to set up radius points, this will assist you run squaring the pool.

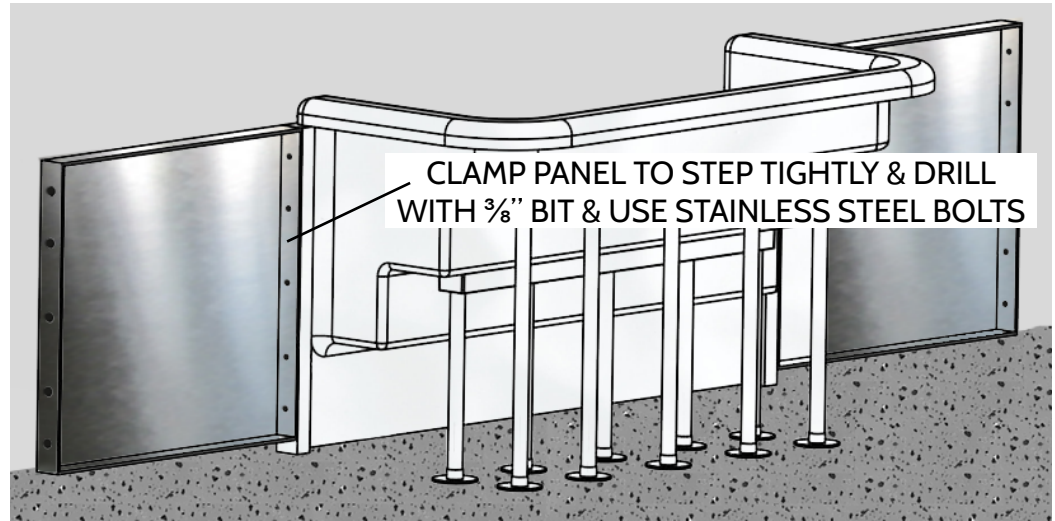

TYPICAL BULLNOSE STEP



TYPICAL CANTILVER STEP

SWEETWATER STEP AND SWIM OUT INSTALLATION

Steps and swim outs are installed in the same manner. Start by setting the step in the excavated area according to the Pool Layout and Dig Dimension Drawing. Use supplied step support system. With the step in place, clamp the neighboring pool panel to the step, insuring that the face of the step is flush with the panel and that the top of the panel is flush with the bottom of the step coping-receptor nose.

With the panel and step clamped tightly together, drill 3/8" holes through the panel holes into the step flange. Use stainless-steel bolts to secure the panels/braces to the step.

SQUARING THE POOL

- When the panel is fastened together, it is time to align the step and walls together.
- Assure that the face of the panels and the face of the step are flush (refer to image of Cantilever and Bullnose Step to Panel).
- When the correct height, and the panels and steps are all flush, re-clamp the steps to the panels.
- Visually RECHECK the step and panel positions.
- When you are satisfied with step and panel positions, you will be ready to permanently attach the step to the panels using nuts and bolts.
- With the step and panels tightly clamped together, drill 3/8" holes through the side flange of the panel and step.
- Bolt the step to the panels.
- Check the square of the pool; check the diagonals of the pool walls. These measurements are provided on your drawings.
- Check the width at various points along the walls.
- Check overall length of the pool.

LEVELING THE POOL

- Using the laser transit, check the level around the pool.
 - Determine the high point.
 - The high point will become your level benchmark.
 - At points that are lower, you can use patio blocks of various thickness as shims.
- NOTE: Roof shingles can be used alone or in small layers in conjunction with the patio blocks to better fine tune the level.
- RECHECK level
 - The coping can have slight gaps between the butt joints, a coping clip will be provided to cover joints.

NOTE: INSTALL ALL SAFETY LABELS TO THE COPING. LABELS ARE PROVIDED WITH COPING AND LINERS.

SECURING THE STEP

- Place a 2" x 6" piece of wood that is longer than the step is wide in front of the step.
- Secure the wood in place by driving rebar if front of the step, this will keep the step from moving when the concrete collar is poured.

ROUGH PLUMBING

- At this point, you will want to install the plumbing fittings.

CHECK LOCAL AND STATE CODES FOR PROPER EQUIPMENT AND APPROVED FITTINGS

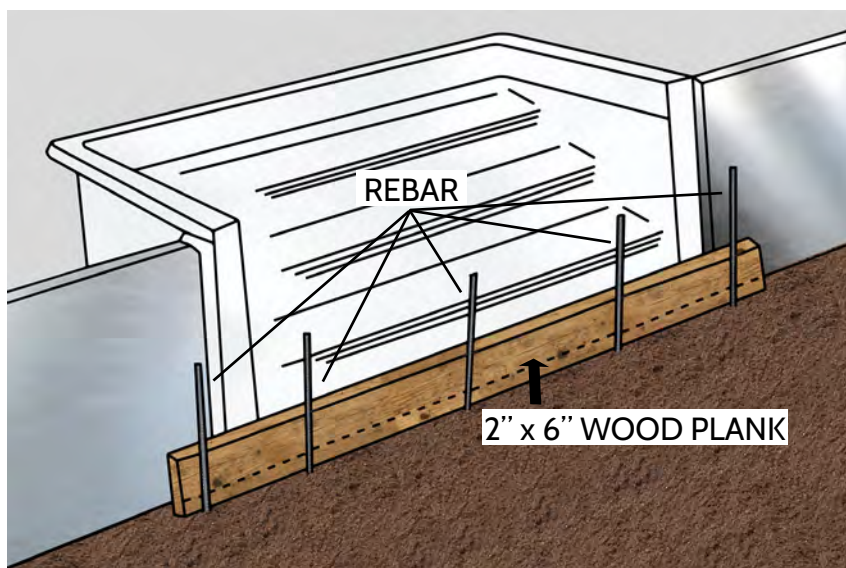

MAIN DRAINS

- **MUST BE DONE BEFORE BOND BEAM IS INSTALLED**
- **TWO MAIN DRAINS MUST BE INSTALLED OR NO MAIN DRAINS - IT IS THE LAW**

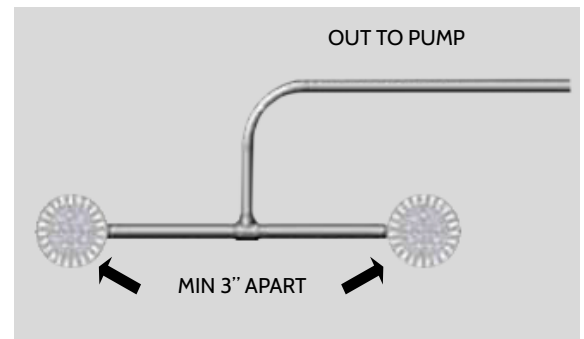

The main drains will be placed in the center of the hopper pad. Dig a 1' wide by 18" deep hole for each main drain. **MAIN DRAIN INSTALLATION MUST ADHERE TO THE VIRGINIA GRAEME BAKER ACT OF 2008.** See www.poolsafely.gov for more information.

CHECK WITH YOUR LOCAL BUILDING/ZONING OFFICE FOR APPLICABLE CODES.

Dig two holes at least 3' apart in the hopper, 1' in diameter and 18" deep. Partially fill the holes with approximately 14" of rock. When the main drains are correctly positioned in each hole, the top of the drains should be at the finish grade, and there should be 4" to 6" of each drain exposed above the rock. The remainder of the hole must be filled with concrete to secure the drains in place. **THE MAIN DRAIN MUST BE SET IN CONCRETE.** To install your plumbing line, dig a small trench in the hopper, starting at the main drain, crossing the hopper, up the side or back wall slope (whichever is closest to the filter), and out under a panel. Set your line, cover with dirt and tamp. Leave the main drain faceplate and gaskets off until the liner is installed.

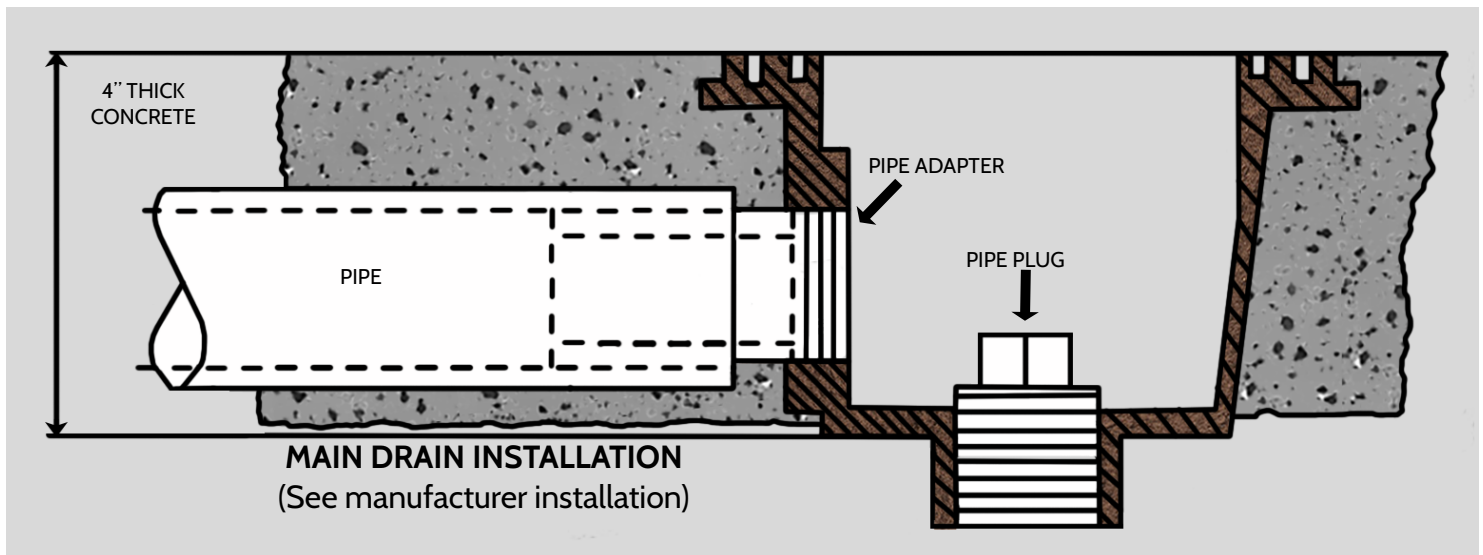

RETURN FITTINGS

- On Polymer Walls, return fittings can be located on any section of the pool wall. On Steel Walls they are pre-cut.
- The returns are designed to work with the skimmer to produce a proper flow pattern that aids the skimmer(s).
- A return fitting hole is a 3" hole that is 12" to 15" down from top of panel's top flange.
- Drill holes from back side of panel, out of the way of any ribbing in panel.
- After hole is drilled, slide the return fitting through the front side of the panel with thread side first.
- Install nut snugly.
- Do not attach the faceplate at this time, you will do that after the liner is installed.

INSTALLING COPING

- Prior to installing coping, run strings the length of all walls at the top of the panels (this will be used as proof that the walls are straight).
- Coping is used as a perimeter or edging of the pool and also to hold the liner in place.
- Start with a corner piece, aligning the center of the coping to the center point of the panel.
- Secure the coping to the panel using the self-tapping screws provided with the coping at a maximum of 12" apart.
- Next, install straight coping with 1/4" gap at the joints of the straight and radius coping.

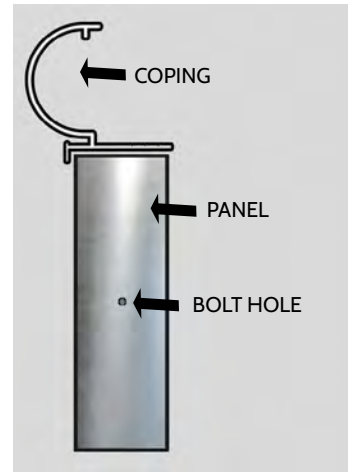

Bullnose Caplock



Bullnose Rimlock

BULLNOSE COPING



Cantilever Caplock



Cantilever Rimlock

CANTILEVER COPING



Flex Radius

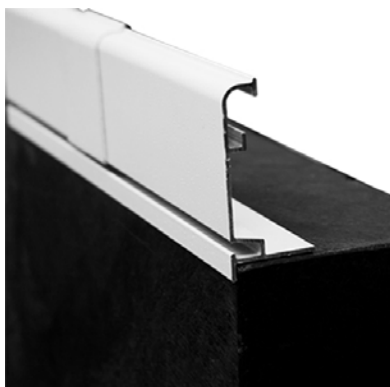

Flex Rimlock

FLEX COPING

WE OFFER CUSTOM COPING AS WELL

SKIMMER(S)

- Typically the skimmer panels are precut.
- If so, follow the skimmer manufacturer's installation manual.
- Different manufacturers use different skimmer configurations and gasket systems.
- Tape off the top of the skimmer so that debris does not enter skimmer body.

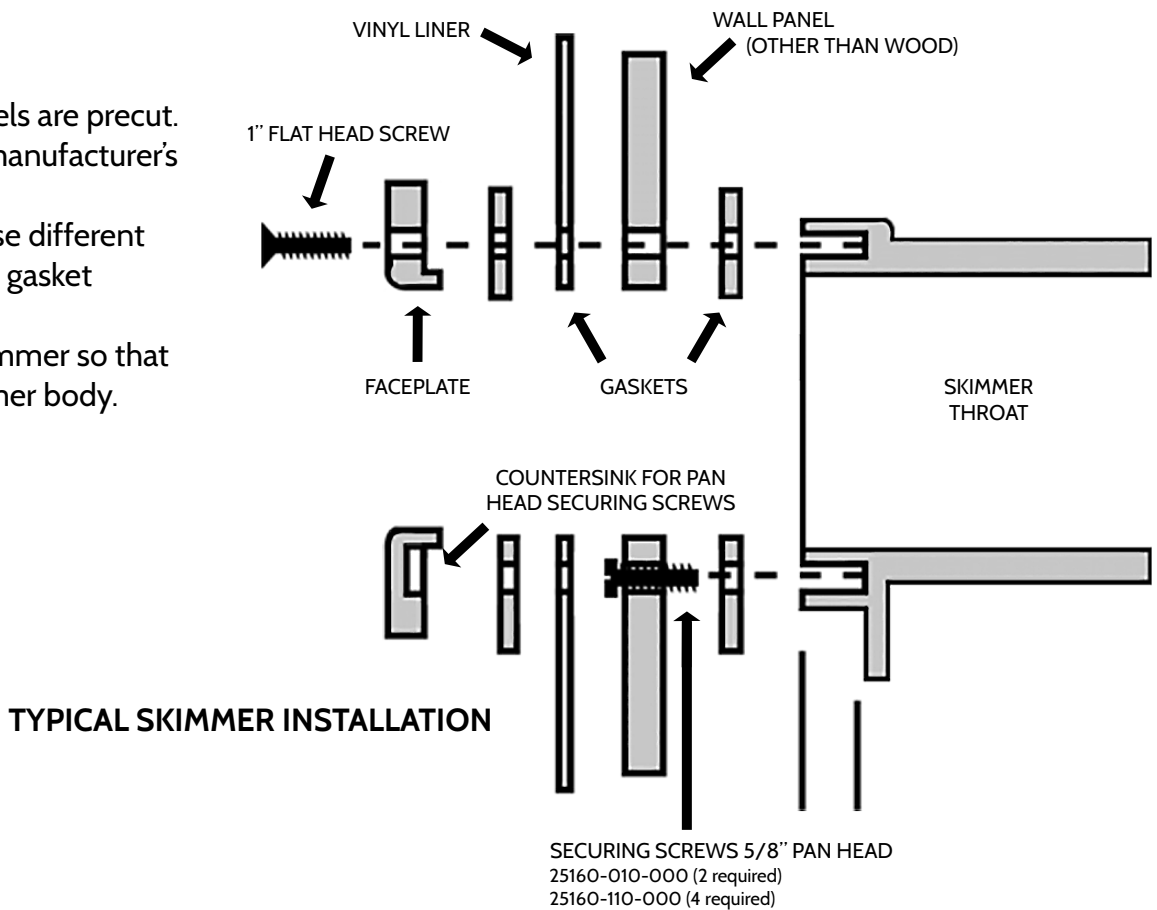

LIGHT(S)

- Typically the light panels are precut.
- If so, follow the light manufacturer's installation manual.
- Different manufacturers use different light configurations.

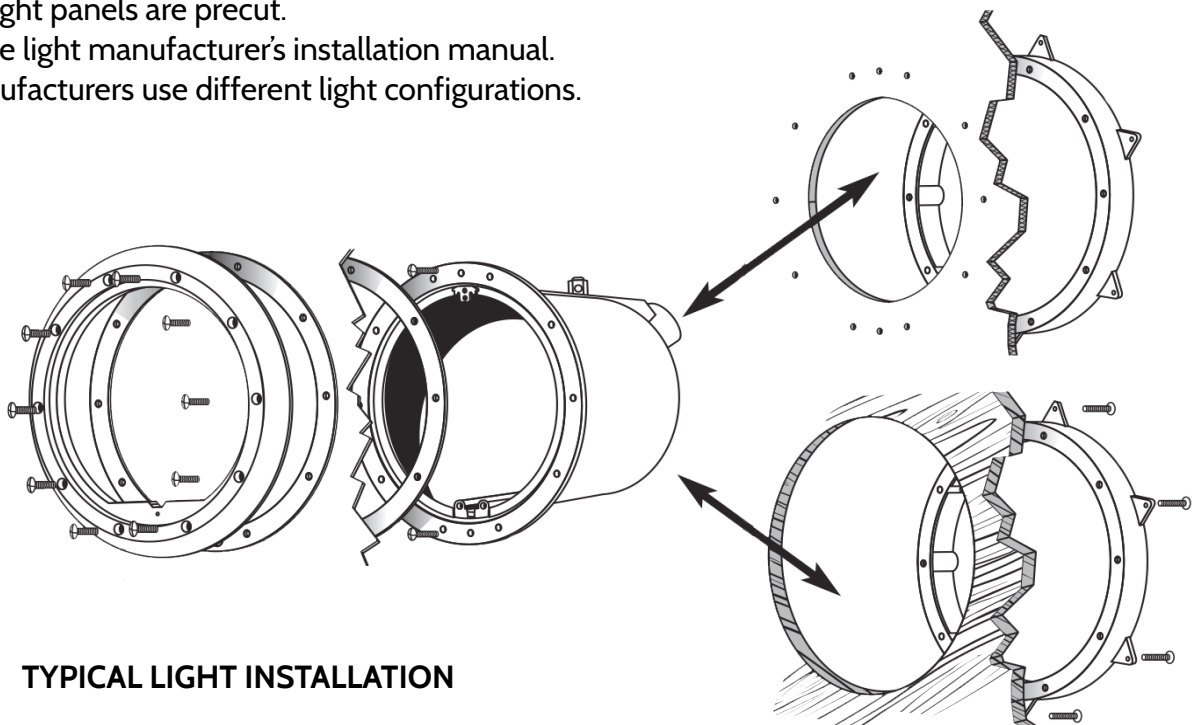

POURING THE PERIMETER COLLAR (BOND BEAM)

NOTE: CHECK WITH YOUR LOCAL BUILDING/ZONING OFFICE FOR APPLICABLE CODES.

Rule of thumb: 1 yard of concrete per 12-14 linear feet of pool. A 16' x 32' rectangle would take 7-8 yards of concrete, 6" to 8" thick consistently.

NOTE: Make sure any plumbing that must be run under walls is marked and out of the way of the concrete.

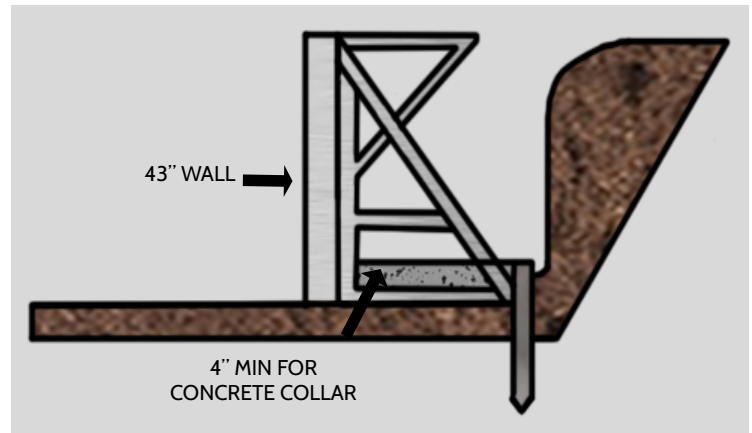

- The collar secures the wall structure's position.
- Make sure there are no openings or gaps under the step or panels.
- Run sting lines on all straight panels to confirm they are flush with the string line.
- Pour the concrete carefully and slowly around the perimeter to keep the walls from moving, have concrete slope away from pool walls.
- After concrete has been poured and is still wet, recheck that the panel is plumb and wall alignment is straight as compared to strings.
- Step area should have concrete up to first tread.

SONO TUBES

Grasp the deck supports and break the rings free from the center of the brace. Push the rings into the sockets until they lock into place, then place a 6" tube (cardboard or DWV pipe) into the supports and cut to proper length. Pour the tubes full of concrete when you pour the collar. This will provide a vertical column to support the deck.

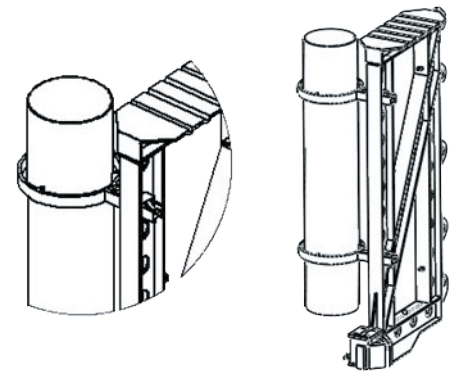

SONO TUBES PLACED AROUND POOL

PREPPING BOTTOM

- The rough excavation should be 2" below finished depth.
- Your strings should be set up at finished depth.
- String the pool in sections based on liner manufacturer's dimensions.
- Place rebar pins at shallow end break points, the pins should be butted up to the walls.
- Locate the front and back sections of the deep end hopper by stretching pins width-wise at proper length (on a 4' back slope you will place pins 4' from the back wall at bottom of wall).
- Continue doing this for both width and length of bottom measurements.
- All dimensions are from top of panel and not top of coping.
- Find the finished pool bottom grade by using a plumb bob at all string intersection points in the deep end.
- Drive pins into each corner of the hopper at the point of which the plumb bob lands.
- Attach string lines to the pins at the proper finished grade.
- "X" the strings to confirm proper depth on all flat areas.
- Do the same in shallow end.
- Clean all loose debris, rocks, sticks, etc., from pool.

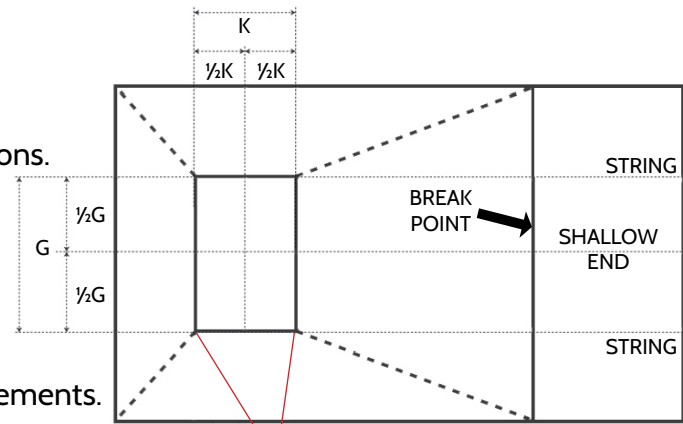

HOPPER STAKES AT INTERSECTION OF STRINGS

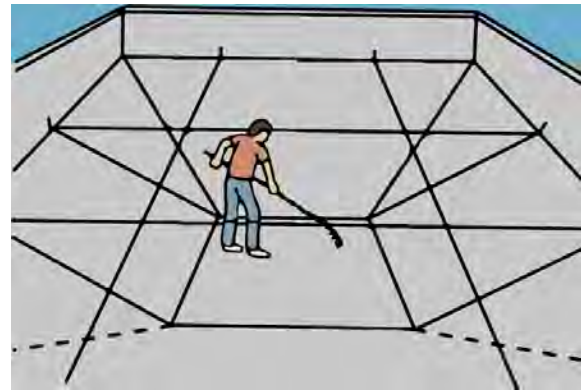
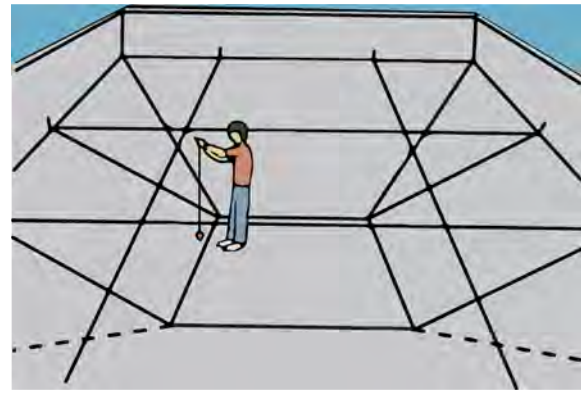

BOTTOM MATERIAL

NOTE: There are varieties of materials to use for pool base, sand/cement, and vermiculite/cement.

- Sand/Cement 5/1 Ratio (sand to cement)
- One ton of sand equals one cubic yard.
- One ton (1 cubic yard) will cover 162 sqft of area.
- Use Type II Portland cement.
- Mason sand is the best and cleanest to use.

FORMULA FOR SAND/CEMENT MIXTURE

- Determine surface area of pool (length x width) a 16' x 32' pool is 512 sqft.
- Multiply by 1.15 ($512 \times 1.15 = 588.88$ sqft) this is the total area to be covered by the bottom mixture.
- One cubic yard of sand will cover 162 sqft. So divide total area by 162 ($588.88 / 162 = 3.63$ cubic yards or $2000 \times 3.63 = 7270.00$ pounds of sand).
- Divide pounds of sand by 5 (5 to 1 ratio) $7270 / 5 = 1454.00$ lbs of cement.
- Check on weight of Portland cement bags and divide pounds of cement by bag weight for total bags needed.

For vermiculite please review manufactures directions.

TROWELING THE BOTTOM MATERIAL

- THE SMOOTHER, THE BETTER!
- NO rocks or pebbles
- Trowel from the deep end toward the shallow end.
- Start on back slope.
- Use string lines to confirm material thickness.

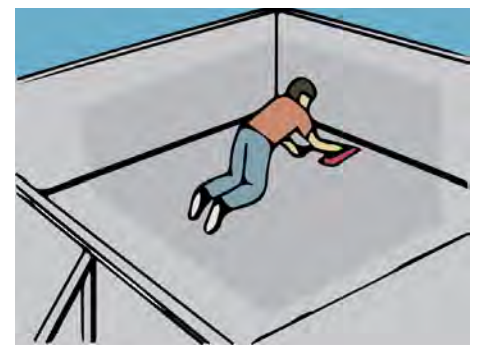

Starting in the hopper end, bring the pool bottom up to finish grade with a damp sand/cement mixture, or pool base mixture. Trowel smooth.

VINYL LINER INSTALLATION

General Information

Vinyl liners should be stored in areas with temperatures above 50°F to prevent excessive shrinkage and permanent folds in the vinyl.

Cold Weather Installation

When installing a liner in temperature of 65°F or lower, store the liner at 70°F to 80°F for at least 72 hours prior to installation. When the bottom is , bring out the liner and drop it as quickly as possible. Try to drop the liner in direct sunlight to help seat it properly. Do not leave a boxed liner exposed to the elements.

Tools Needed For Liner Installation

Commercial Vac/Blower 2HP 130 CFM (REQUIRED)
Screwdrivers
Phillips and Straight
Razor Knife

Garden Hose
Broom
Two to Four People
Sand Bags

Liner Installation

Vinyl liner installation can be fast and easy; just follow these guidelines!

REMEMBER, if you cut anything before all the wrinkles are gone, YOU OWN IT.

1. This installation page is a brief outline of what needs to be done when installing a vinyl liner. For further information regarding liner installation refer to your complete pool installation manual or contact your local dealer.

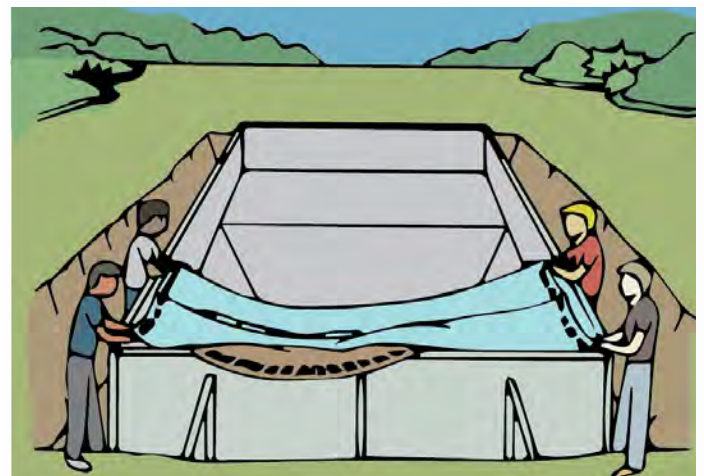

2. Tape all seams at panel joints inside the pool to secure good vacuum suction (remove the rest).
3. Broom sweep and/or vacuum hard bottom of any foreign objects (dirt, pebbles, etc.).
4. Secure main drain, skimmer, high and return/inlet gaskets using 100% silicone such as RTV.
5. You are now ready to install the liner. Vinyl liners are best installed in warm sunny weather.
6. Carefully place carton at deep end with arrows on box facing the shallow end.
7. Take liner out of the box and unroll, center up liner and unfold top 2 layers to find hang tab. Pull the liner toward the shallow end, this will take 3 or 4 people, 2 to hold and feed the liner and 2 to pull some extra in the shallow.
8. The shallow material of the liner will be on top.
9. Place liner into the bead receiver for the entire shallow end first. Once liner is seated against the step, place bags up against where the floor and step meet at the step. This insures that the material does not creep down toward the deep and away from the set during filling. Finish putting bead into the receiver track for the rest of the pool. Corners should be marked with tape for reference and the deep end of the pool should be stamped "deep end" on the backside of the liner.
10. Set up the vacuum - help liner into position. Once liner is positioned and seated you may wish to also sandbag along the break line.
11. "Important Note" - do not cut main drain, skimmer, stairs, or returns until completely satisfied with liner fit.
12. Where plastic walk-in steps are used this area must be sealed off to get proper vacuum. Place the liner up tight to the step and place sand bags in shallow end against the face of the step, lay plastic over the top of the step and secure it to the step and the liner.
13. Only if satisfied with the liner fit, and when 1'6" of water has filled in the deep end, secure main drain faceplate.
14. Leave vacuum running continually until 1/0" of water is in the shallow end.
15. At this point, the vacuum may be shut off and the hose removed form behind the liner.
16. Do not install the outlet and skimmer faceplates until water reaches 1" below bottom outlets and skimmer.
17. IT IS THE RESPONSIBILITY OF THE POOL OWNER TO PROPERLY RE-INSTALL THE REPLACEMENT OF THE ROPE ANCHOR DEVICES AND THE ROPE AND FLOAT ASSEMBLY FOLLOWING THE INSTALLATION OF THE LINER.
18. Never drain the pool without consulting a pool dealer.
19. Improper installation of liner may void the liner warranty.



LINER BEAD INSTALLATION

SWEETWATER STEP AND SWIM-OUT LINER INSTALLATION

Use sand bags to hold the liner in place. Use a plastic sheet to cover the top of the step section. Use duct tape to seal the plastic over the steps and seal all openings around the liner. When the water is 6" or more in the shallow end, install faceplates, using stainless-steel screws and following the manufacturer's instructions. Carefully use a razor knife to cut out the liner material inside the step faceplates. Install screw covers following the manufacturer's instructions. Trim the vertical faceplate to meet the bottom of coping. (You may have to trim the faceplate at installation depending on your deck).

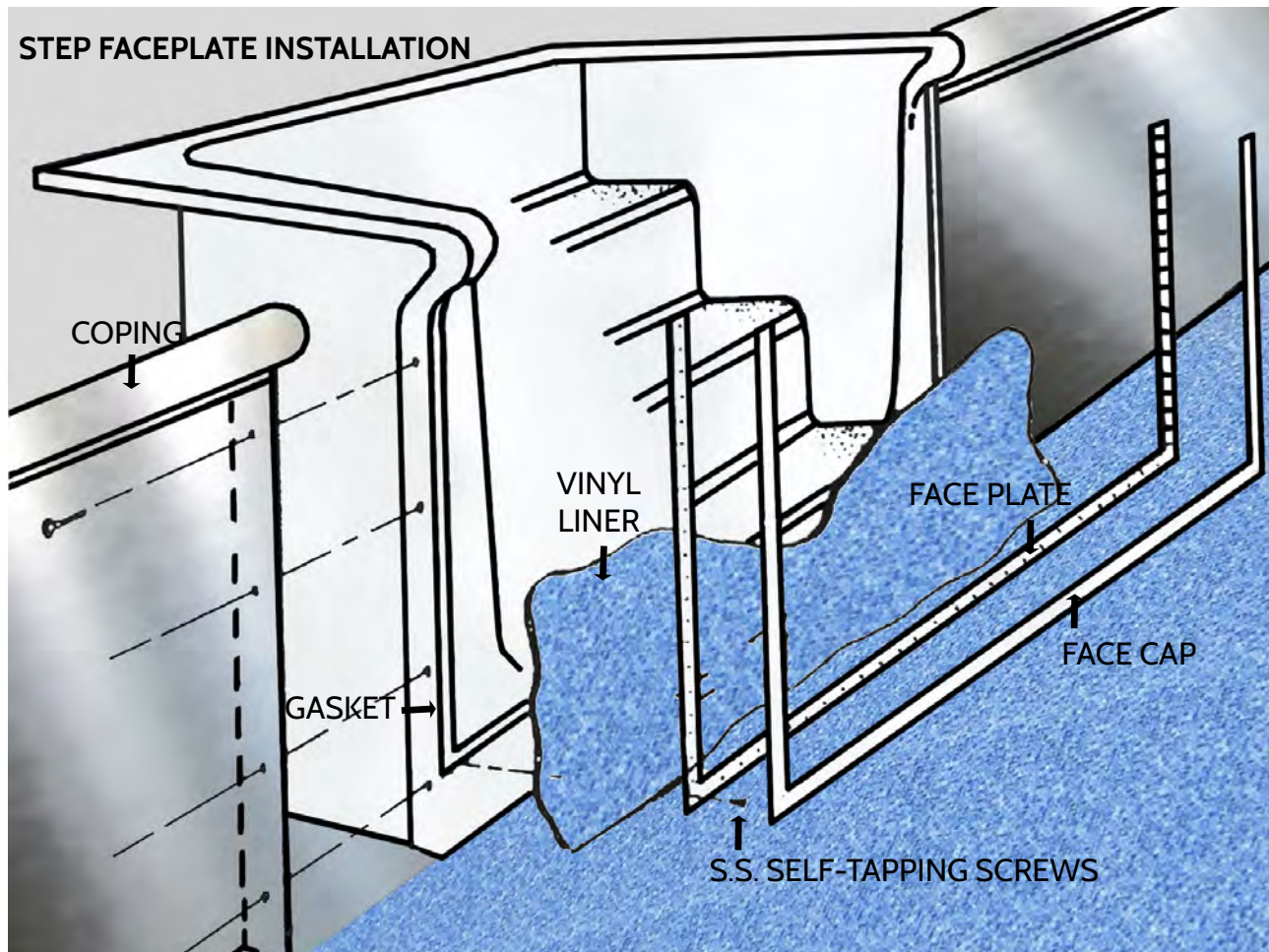

BACKFILLING YOUR HYDRA POOL

There are several methods used in backfilling the pool. One method is to backfill as the pool is being filled with water, keeping the water level even with the backfill material. Again this is just one method dealers over the years have developed there own ways to backfill pools. You can use any non-expansive material such as clay to backfill your pool, bring the backfill material to the top of the braces, leaving the top of the brace exposed. IF USING DIRT, PLACE IN WET & COMPACT LAYERS.

SAFETY ROPE

Use the APSP Guidelines to determine the correct position for the safety rope. Install coping-mounted rope eyes in this position and fasten the safety rope, following the manufacturer's instructions.

INSTALLING CONCRETE DECK *WE RECOMMEND YOU HIRE A PROFESSIONAL

1. Concrete should be a minimum of 6" thick at the pool edge and taper down to 4" on the outer edge.
2. For proper drainage, the slope must fall 1/4" for every 1' of width.
3. Broom-finish the concrete for a non-slip surface or apply other concrete toppings, such as cool deck.
4. Use additional support (piers) down to undisturbed earth when the deck extends more than 4' from the pool wall.
5. Pour the deck at least 8' wide where the diving board is installed.

DETAIL DRAWINGS

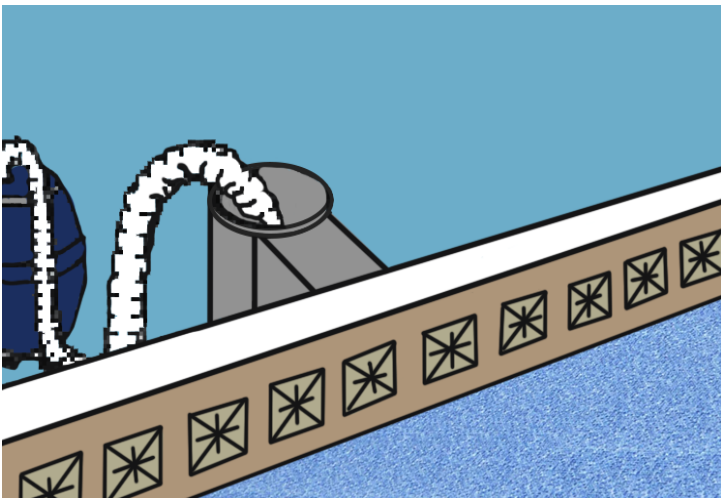

As soon as the liner is pulled into place, start filling the pool. Leave vacuum on until water is 6" deep in the shallow end.



When water level is 2' above panel bottoms, screw skimmer, returns, and light faceplates with gaskets to wall fittings. Using a knife, carefully cut out vinyl from inside faceplates.

The main drain should be mounted in a concrete pad approx 24" x 24" thick. The piping from the main drain should be installed and run out from the pool area before pouring concrete bond beam around pool.

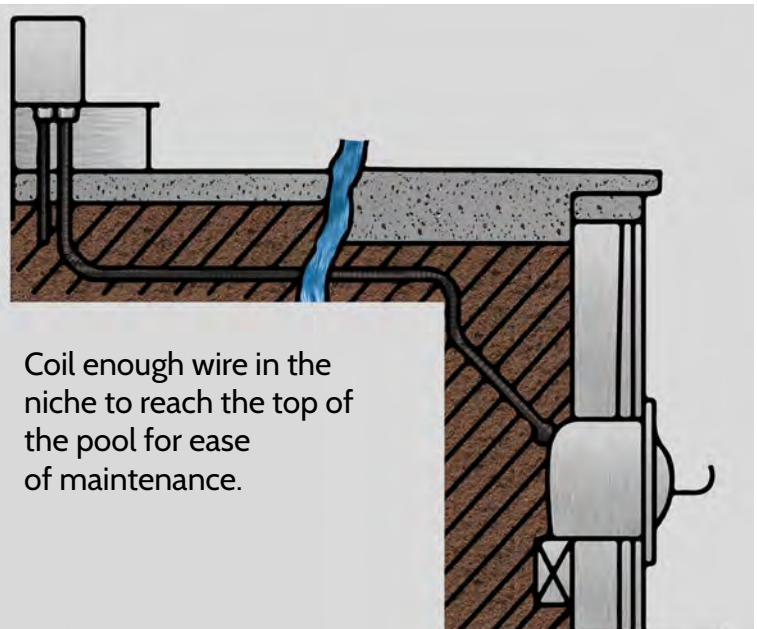
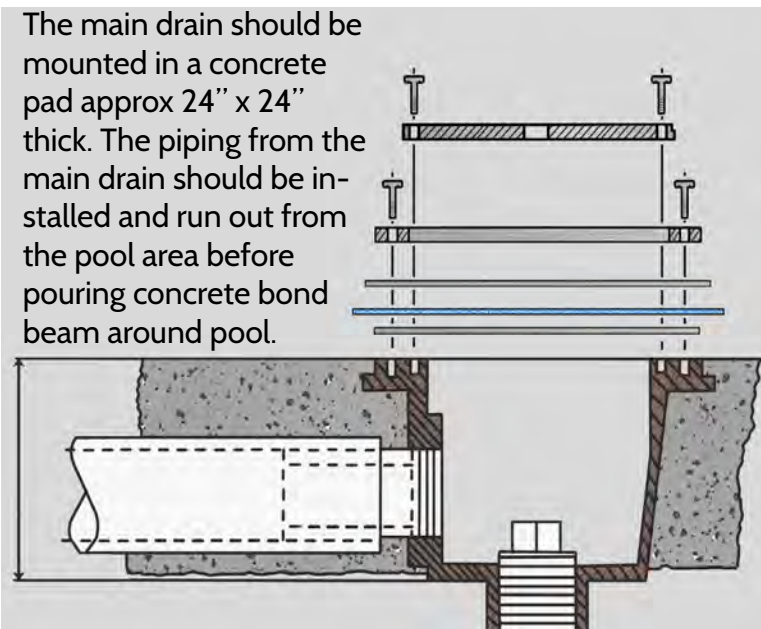

Coil enough wire in the niche to reach the top of the pool for ease of maintenance.

STEPS & RAILS

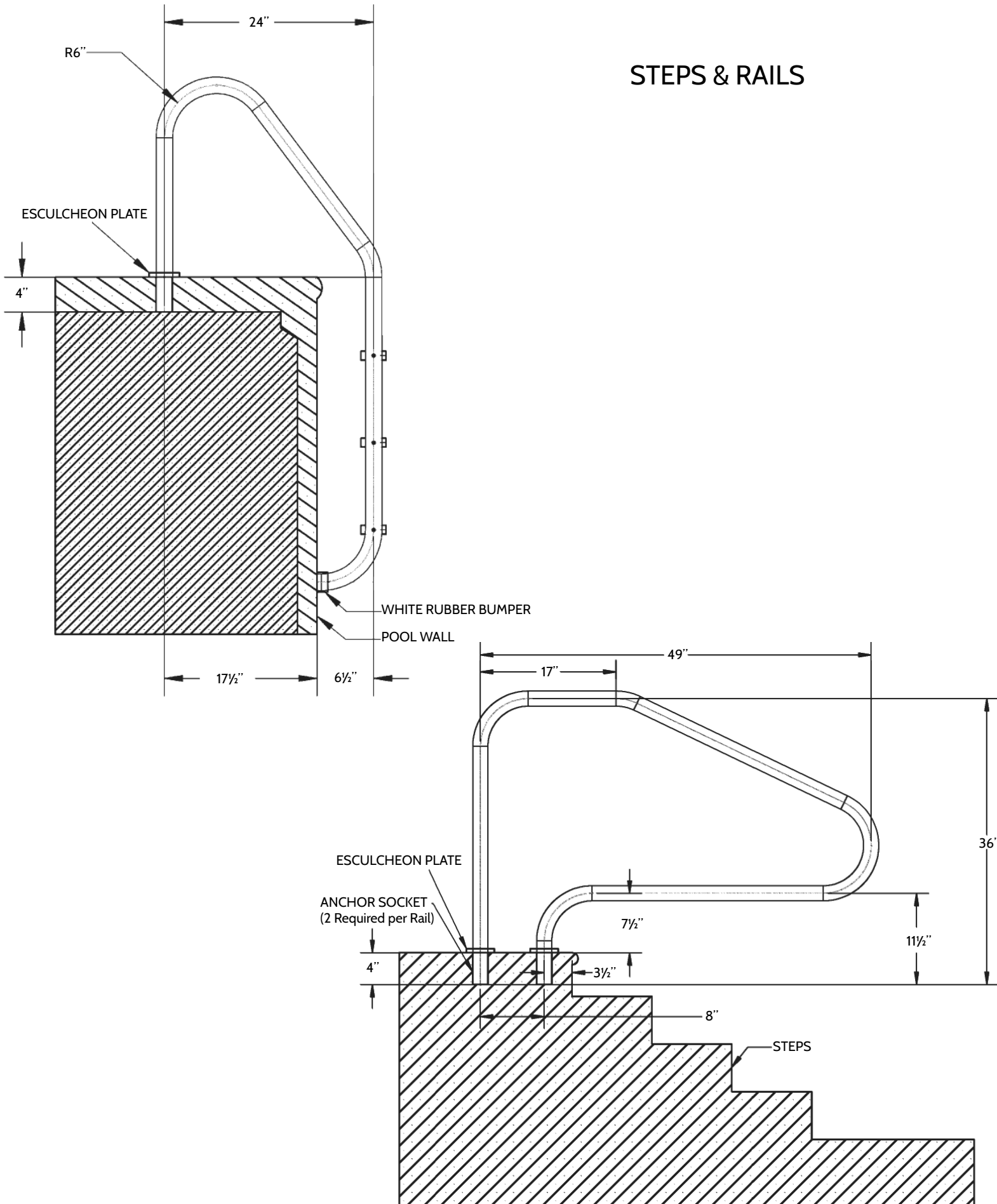

POOL PLUMBING DIAGRAMS

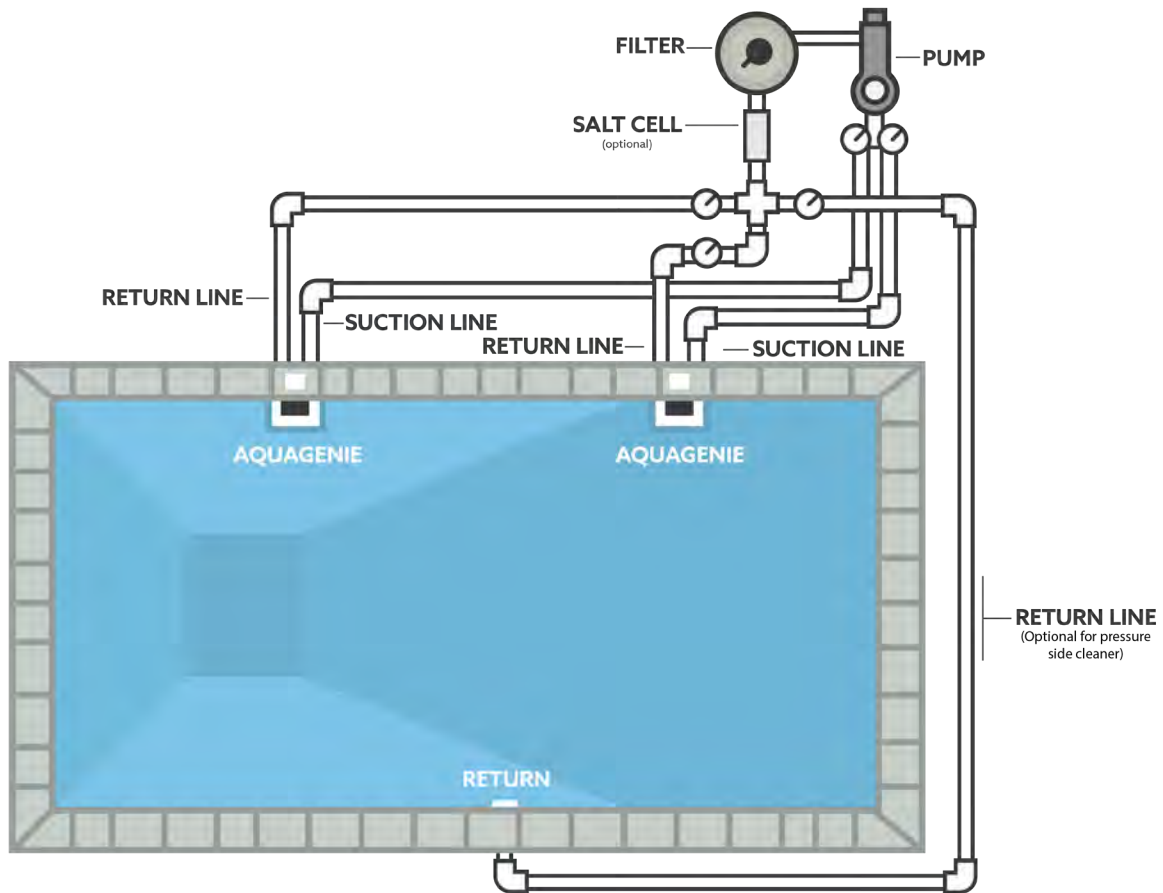
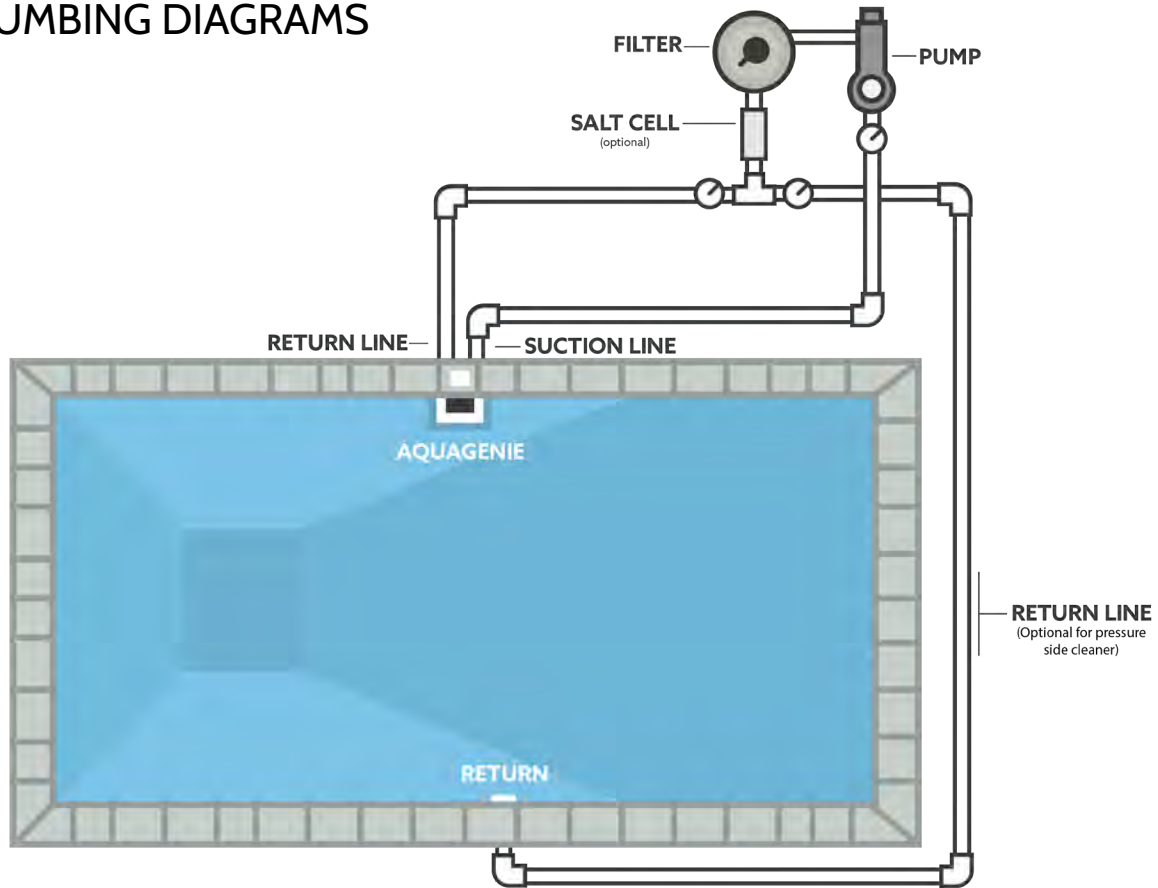

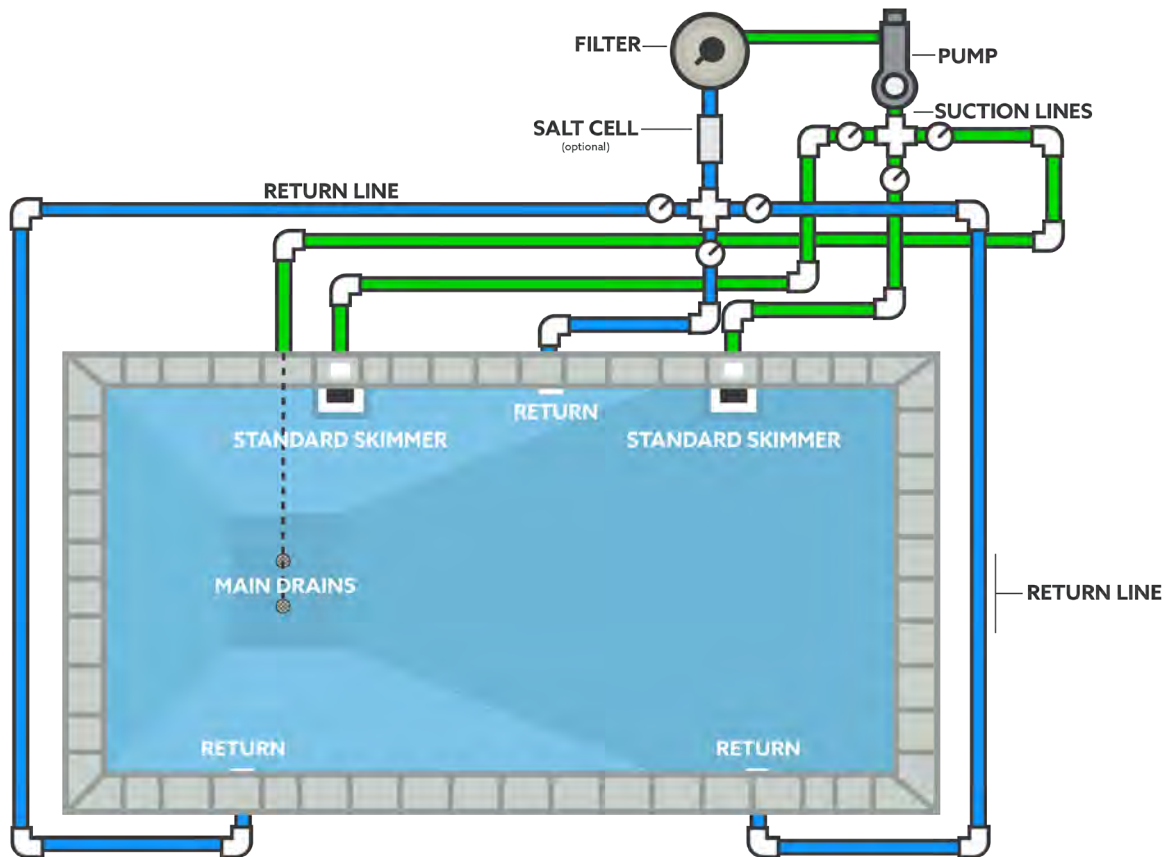
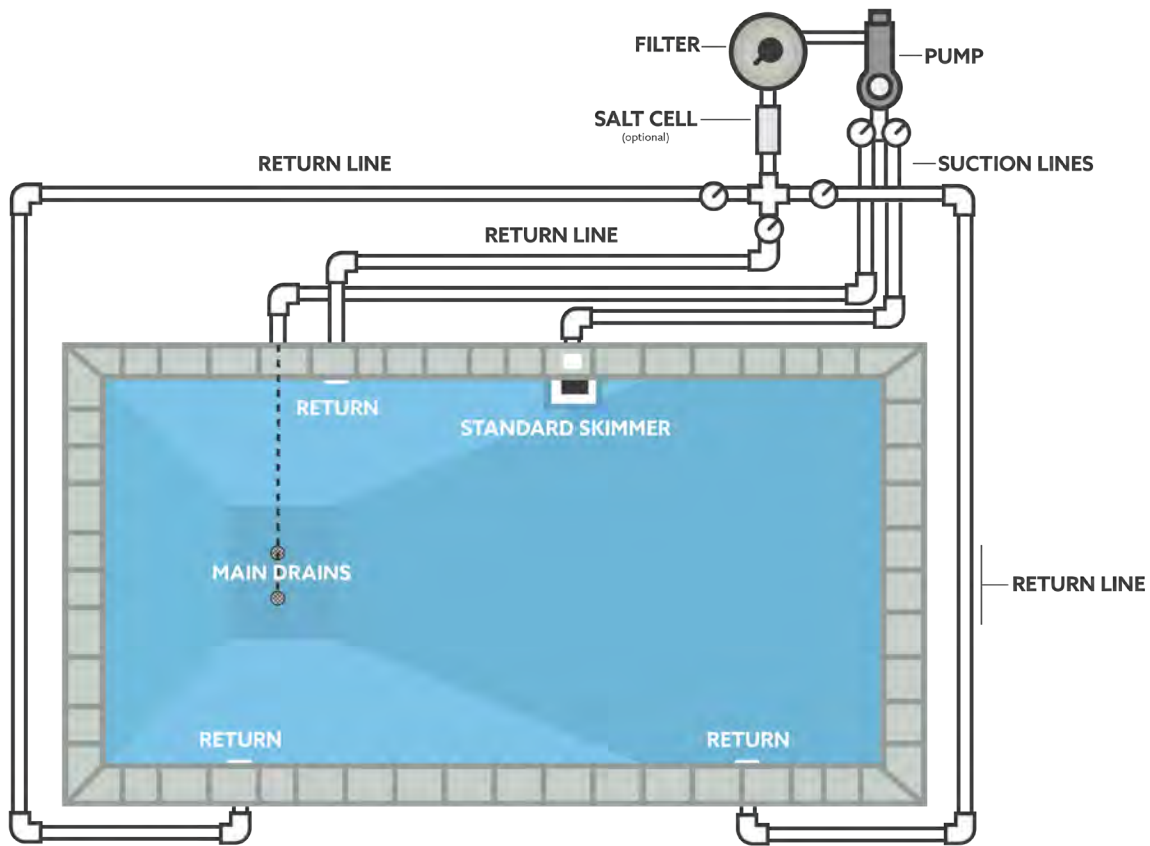

STEEL PANEL DIAGRAM

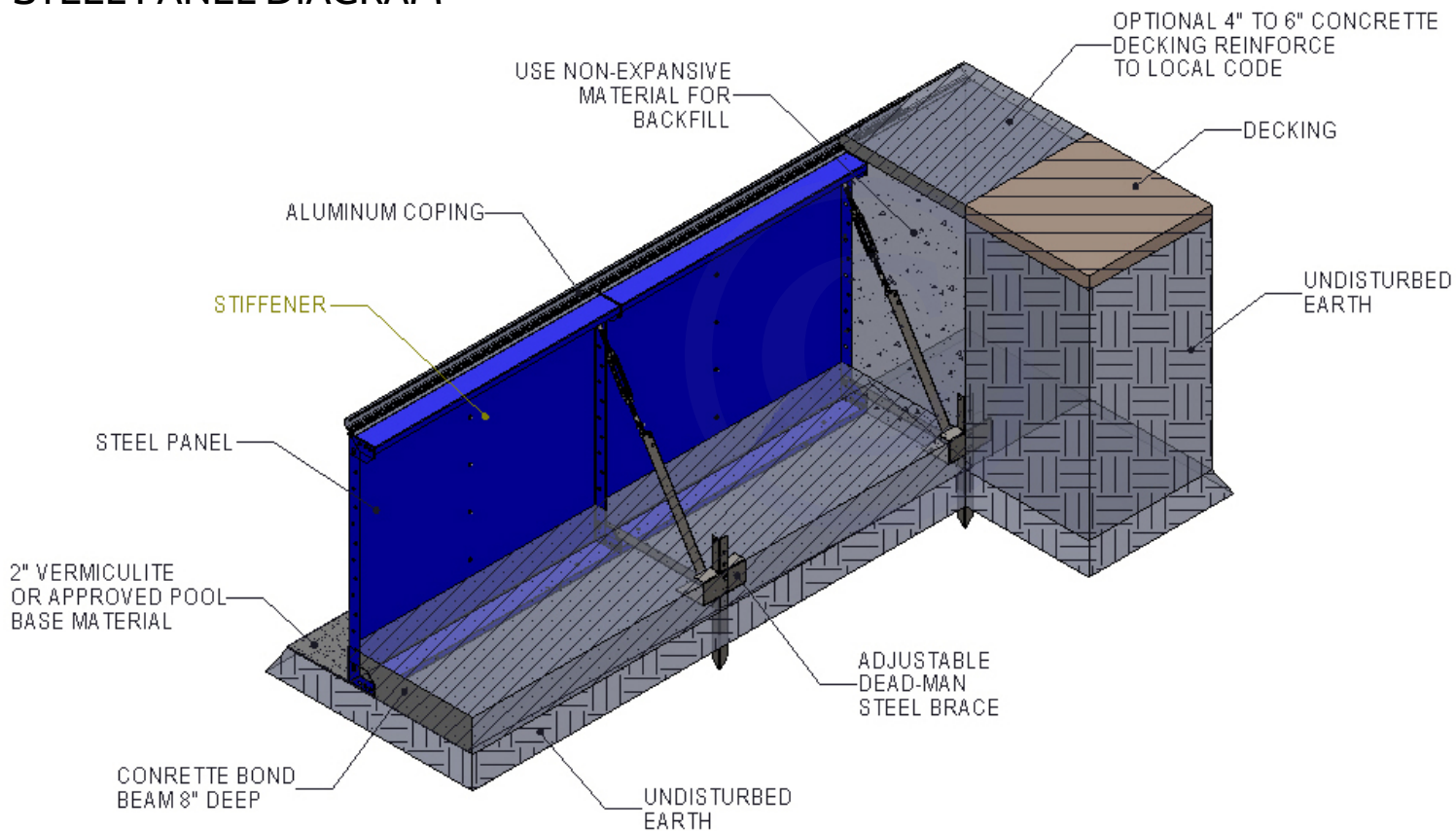

POLYMER PANEL DIAGRAM

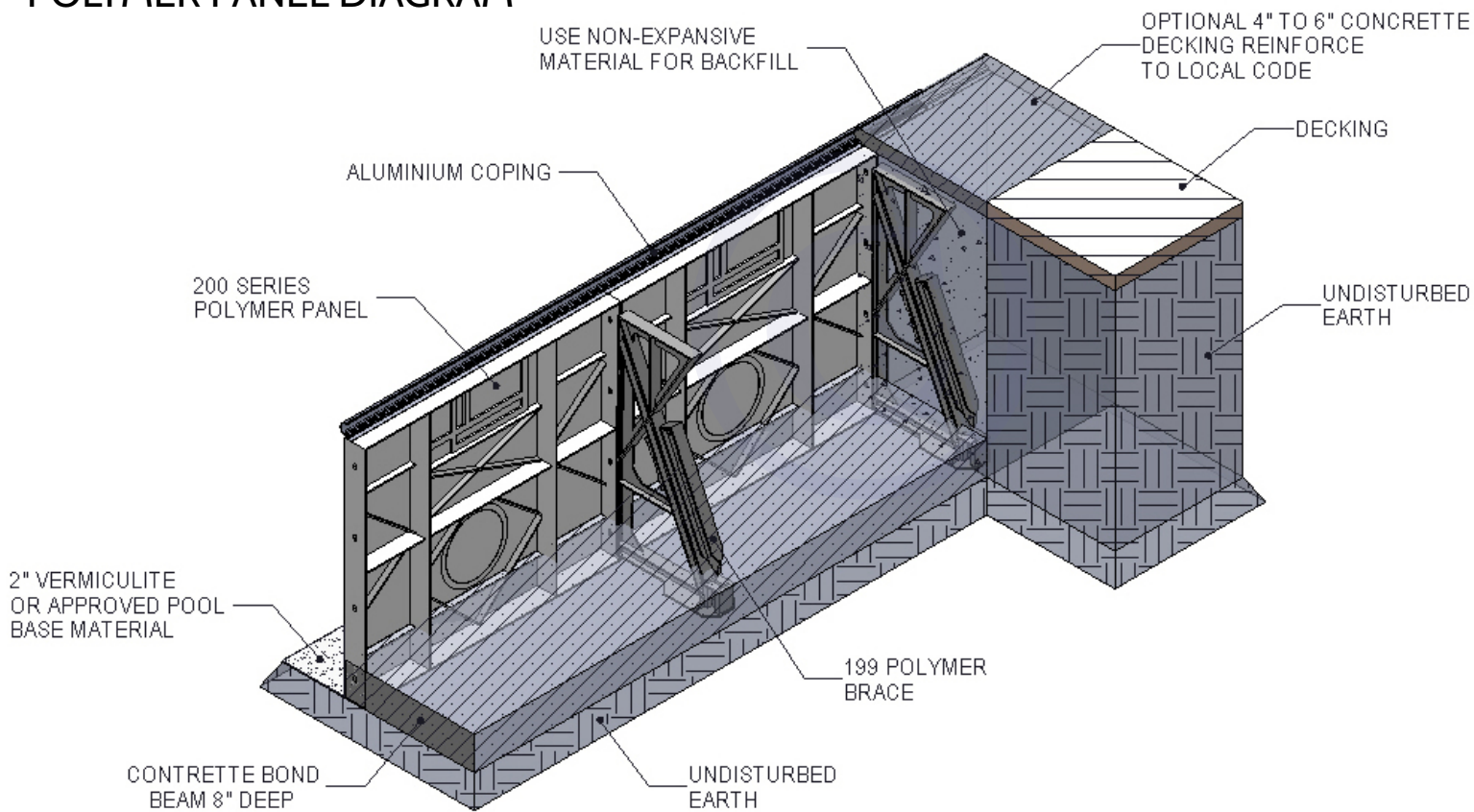

FREQUENTLY ASKED QUESTIONS

Excavation Questions

Q. How deep should I excavate the shelf/shallow end of the pool?

A. Once you establish the pool elevation/benchmark, excavate 42" or 48" down, which is the height of the Hydra, Pinnacle, or Cornerstone polymer or Samson steel panel without the coping attached. This is depth of the shelf around the entire pool where the panels will sit. This shelf is the same in the shallow end as well as the deep end. The entire shallow end should be excavated to the same depth as the shelf. You will constantly be using two terms, dig dimensions and finish dimensions. Be sure you understand both terms and how to move between them during the construction of your pool.

Q. How deep should the hopper in the deep end be excavated?

A. Always dig the hopper in the deep end 2" deeper than the pool's finish depth. Example: If the finish depth of deep end is 8', dig hopper area to a depth of 8'2" from the benchmark or the top of the 42" or 48" panel without coping installed. This will allow for the installation of 2" of bottom material, such as vermiculite (pool base) or sand-and-cement mixture in the bottom of the hopper.

Q. Will excavating the shelf area around the pool leave enough room for the braces?

A. The panel line you have will dictate the brace size and the amount of over-dig in the shelf area. Requirements are as follows: Hydra requires a 24" over-dig, Cornerstone requires a 24" over-dig, Pinnacle requires a 36" over-dig, Samson Steel requires 30" over-dig, Extreme requires a 24" over-dig. These are minimum requirements to allow room for the brace and to work in the shelf area.

Q. The installation manual advises not to over dig, what does this mean?

A. Extreme care should be taken when digging any depth or slope of the pool, especially in the hopper or deep end of the pool. Carefully mark the shelf area where the walls will sit using marking paint or strings with pins. Do not let the excavator dig past your marks or strings. You may want to hand shovel (trim) during this procedure to keep the excavator away from the shelf, thus keeping the shelf edge intact where the walls will sit. Keep in mind that all walls in the hopper area slope at various angles, thus the term "hopper bottom".

Q. When digging and encountering ground water, what are some options?

A. The most common option is to use a self-priming pool pump like the one for your pool package. All plumbing should be schedule 40 PVC installed as shown in the installation manual. Cap the pipe and drill as many 3/8" holes as possible in the tail-piece buried in the gravel/rock below grade. Make sure all plumbing joints are tight so you can pump the maximum amount of ground water from beneath the pool during the construction of the pool. You can also use a sump pump as detailed in this manual.

Finish Dimensions Questions

Q. What do finish dimensions refer to?

A. Finish dimensions refer to several areas of the pool. Most of the time they refer to the interior of the pool, both length and width, as well as depth measurements. Example: A 16' x 32' rectangle pool that is 40" finish in the shallow end and 8' finish in the deep end would measure 16' wide and 32' long on the interior of the pool walls. The depth of the pool would be measured from the top of the wall (without coping attached) to the finish bottom material. The bottom material comes 2" up the wall panels to the finish grade following the entire inside perimeter of the pool. Panels have a scribed line at the 2" mark.

Q. What standard dimensions are on the drawing you receive with your package?

A. All dimensions on your drawing are finish dimensions, with the exception of the panel-shelf detail. Remember to add 2" to all depth dimensions to allow for the 2" of bottom material needed later. This applies to the panel shelf as well. The panels are 42" high, and the finish inside the pool is 40", up 2" on the panel. All depth measurements are from the top of the panel with no coping installed.

Wall Panel Installation Questions

Q. How tight should the panel bolts be?

A. All panel lines need to have the bolts tight and secure. Do not over-tighten. Two of the panel lines (Hydra and Cornerstone) have side flanges that are smooth and require using the alignment bolt to properly connect one panel to the next. One of the panel lines (Pinnacle) has stud/socket alignments on the side flanges of every panel. This allows for instant panel alignment and lateral strength.

Q. How level should the panels be?

A. As with any construction project involving walls and footing, the walls need to be level, square and plumb (perfectly vertical) before the footer/collar is poured. After the panels are bolted together, they need to be leveled by using the transit to level all panels to every other panel. While this step is progressing, continue to square the pool also. After the pool panels are level and square, make sure they are plumb. After this is complete, and after the braces are all set, it is time for the collar to be poured.

Q. How do I bolt the panels to the step, in-wall ladder, cozy cove spa or swim-out?

A. After leveling the step following the manufacturer's instructions, clamp the wall panel to the steps so that the flanges on the side of the step align with the top and face and face of the panel. If wall stiffeners are in your way, mark all holes with a marker, remove step from panels and drill holes where marked on step flanges. Remember, one panel line has an alignment feature on one side that must be removed at this time so the steps will bolt up flush to the panel. The Hydra and Cornerstone panels do not require this step.

Q. My soil is too rocky or hard for the polymer stakes, what can I use?

A. Steel stakes are available as an up-charge on all panel lines. Hydra, Cornerstone HO2466, Pinnacle HO3110.

Q. What consistency should the concrete be for the collar (bond beam) be?

A. When ordering concrete for the bond beam/collar, it should be 3,000 psi rating with a minimum of 5" slump. This allows for the concrete to flow around the braces. (Note: Always check walls for straightness and plumb before the concrete sets).

Aqua Genie Installation Questions

Q. How is the Aqua Genie Installed?

A. The Aqua Genie is mounted from the back of the panel with the face of the Aqua Genie extending through the precut hole in the panel. It attaches to the back of the wall eight number 10 x 3/4" self-tapping screws.

Q. The Aqua Genie has three holes for plumbing lines, which goes where?

A. There are two holes below the point at which the basket sits in the main body of the Aqua Genie. One is 1-1/2" and the other is 2". One will be your suction going to the front of the pump, located at the equipment pad. The other will be plugged in such a manner to ensure a watertight seal. The third hole is located under the throat of the Aqua Genie; this is where the clean filtered water returns from the filter. Two terms used often in the pool industry are suction and return. The pump located at your equipment pad is the center point. If you are standing over the pump, any plumbing lines coming from the pool to the front of the pump are called suction lines. Any lines leaving out of the pump to the filter, heater, salt generator and the like and eventually going back to the ground or pool are called return lines.

Q. Where should the Aqua Genie be placed in the pool perimeter?

A. Always locate the Aqua Genie as close as possible to the center of the long wall on a rectangle pool. Larger rectangle pools may require two, L-shaped pools may require two or more, and free-form pools have specific requirements that are noted on your layout drawing.

Q. Where do I order replacement parts?

A. Visit aquagenie.com for replacement parts. An exploded view with a BOM is provided.

Q. How do I pressure test the Aqua Genie?

A. Place expanding plugs in the bottom on the suction line. Place a blanking plate on the nozzle and plug the stainless steel feeder tube. Fill the lines with air and check the gauge for any drop in pressure.

Q. How do I winterize the Aqua Genie?

A. We recommend using our Aqua Genie winter cover, part 3-H03116N. This covers the inlet and return of the Aqua Genie. With this cover, there is no need to remove the faceplate. Place the cover's bolt through the inlet and tighten until the gasket is snug. Blow out the plumbing lines to remove all of the water. Pour a couple of gallons of RV antifreeze into the suction line underneath the basket.

Q. Why don't I need separate returns when using the Aqua Genie?

A. The Aqua Genie has a built-in return.

Step Installation Questions

Q. How do I support my Sweetwater Steps during installation?

A. Your steps come with our new PVC and ABS step-alignment system. This is your leveling system to support the step during and after installation. This leveling feature attaches PVC legs to the injection-molded tread support mounted under the step treads. The legs will be anchored in the concrete collar when poured around the pool perimeter. With the proper backfill installed, this should give you a lasting foundation for your steps.

Q. When I install coping up to the side of the step, the vertical faceplates on each side of the steps get in the way. What should I do?

A. Cut the vertical faceplate and beauty strip off about 1/2" below the liner track on the coping. This will allow the coping an easy transition from the top of the wall to where it butts up to the side of the step.

Q. When should I remove the faceplate extrusions from the step?

A. Leave them attached until you are ready to install the liner. Remove the beauty strip, and before removing the faceplates, mark right/left and top. The horizontal strip across the bottom of the step should be marked right and left also. **THEY CAN BE INSTALLED INCORRECTLY.** All screw holes are pre-drilled to match the faceplate. The gasket is installed and covers the pre-drilled holes. You will want to align them perfectly when installing the strips over the liner.

Q. Where should I place the step returns if installed?

A. Installation should be on the flat area on either side of the step, as you walk down into the pool. Placement should be about 12" to 15" down from the top of the step. The fitting is #SP1023. This fitting has three gaskets; two rubber gaskets and one fiber gasket. The hole size for the step return is 2-1/2".

Q. When should I put the faceplates on to secure the liner to the step?

A. The water in the pool (shallow end) should be deep enough to push the liner vertical to the step. The liner at the bottom of the step should be at a 90 degree angle from the floor to the step, no space. Once this has been accomplished, attach one vertical faceplate, then the other, to the step. Tighten and secure each screw. Once this has been done, install the horizontal faceplate. If there is any doubt as to how the faceplates are to look when installed, take a picture before removal, showing step detail with beauty strips removed.

Q. How do I support my Sweetwater 6' swim out?

A. The width tread of the 6' swim out has a large surface area. Due to the weight of the water on this area, it is best to support it with concrete block piers. Place 4 piers across the bottom length of the swim out, where the blocks touch the bottom of the swim out. Place a treated or composite bond across the whole length. When the collar is poured, this will keep the blocks in place.

Q. How do I clean the steps and swim outs?

A. You can clean the steps and swim outs with a soft scrub cleaner with bleach. For stubborn stains, you can use an automotive rubbing compound.

Q. I need to replace my step screws, gaskets and faceplates. What parts do I need to order?

A. The step screws are number 10 x 1" pan head stainless steel. The replacement screws are part number H01906,

sold in a pack of 50. The faceplates and gaskets can be ordered and they are part of part numbers H0543UD for the faceplates and 102631 for the gaskets (2 required for an 8' step), holes are not pre-drilled. Use the old faceplates as a guide to drill the new faceplates.

Q. How do I winterize step/swim out jets or main drain?

A. Remove the internal jet. Carefully turn the jet with slow, even pressure. **USE CAUTION WHEN TURNING THE JET, TOO MUCH FORCE WILL BREAK THE INTERNAL TABS AND A NEW JET WILL BE NEEDED.** Place expanding rubber plugs in the jet openings. Remove or open the air valve all the way. Blow air through the lines until the water is removed. For the main drain, blow air until you see bubbles coming from the drains, then quickly close the valve at the pump. Pour RV antifreeze through the air valve and close.

Coping Installation Questions

Q. Do I need to cut the coping to fit?

A. Both our bullnose and cantilever coping require some cutting to fit. This can be done with a hacksaw, swazall, jigsaw or a compound miter saw with a metal cutting blade.

Q. Some of the coping clips pop off. How can I correct this?

A. Make sure the joint where the coping sections meet is even. You may have to tap one or the other with the palm of your hand to align them evenly. Take the coping clip and bend it slightly to a tighter radius. Take a small amount of clear silicone and apply to the inside of the clip before installation.

Q. I have cantilever coping. Where are my coping clips?

A. Cantilever coping does not require clips. You will need self-tapping screws only.

Q. During installation, my coping was scratched. How can I repair the finish?

A. This can be touched up with paint supplied where you purchased your pool kit. It is a specially formulated paint for the coping. It is sold in 12oz cans and the part number is H02974.

Q. Can I tape the coping to protect it when pouring the deck?

A. Painters tape can be used along the coping edge. Apply it prior to pouring the deck. If there is adhesive transfer, use a rag and a product called GOOP or GOO GONE to remove. This is available at most major home improvement centers.

Liner Installation Questions

Q. What if my liner is too big or too small?

A. Vinyl liners are temperature-sensitive. If it appears too big, take the liner out of the track and let it relax in the bottom of the pool. Wait until the early morning to re-install the liner. If the liner appears too small, take it out of the track and let it relax. Wait until mid-afternoon to re-install the liner. In the fall, winter or early spring, keep the

liner in a heated area until ready to install.

Q. My liner bead will not stay in after I installed it. What can I do?

A. An extruded product known as liner lock is available to assist in keeping the liner in the liner track and it is widely available online and in most pool stores.

Q. How do I find the number of gallons my pool holds?

A. Go to hydrapools.com and look under the resources tab to find our pool gallon calculator.

Q. I need to patch/repair my liner. What should I use?

A. Most pool supply or some home improvement stores will carry a vinyl pool liner repair kit. You can also find these kits online.

Q. I ordered a safety ledge, but do not see it in my pool.

A. Sometimes with our liner design software, the safety ledge is designed into the pool. This eliminates the seam.

Q. Where do I find the serial number for my liner?

A. The serial number will be on the warranty card and on the liner. Look in the deep end, on the back of the liner. It will be placed 1' - 2' from the center of the deep end near the top of the liner.

Q. How do I line up the liner of a free form pool.?

A. Look for the seam at the back of the hopper where it meets the slope. Use this to line up the deep end. For the shallow end, look for a seam closest to the break. It will be parallel.

AQUA GENIE

The Automatic Way to Keep Pools Clean and Healthy



OPERATING & MAINTENANCE INSTRUCTIONS

AquaGenie SKIMMER/FEEDER

AquaGenie removes floating debris from surface water much faster than ordinary skimmers. In addition, it provides a constant controlled supply of chlorine to pool water automatically. AquaGenie catches fine dirt, leaves, pollen, floating germ-laden scum before it becomes suspended in the pool water or settles to the bottom. Ten times as much water must be run through filter to remove suspended dirt as to remove dirt caught while still on the surface.

Operation

The AquaGenie feeder is operated by water being returned by the filter to the pool. This clean water is directed down and out through a nozzle slot in the orifice plate. The sheet-like jet of water created by this action causes counter currents which increase the effectiveness of the AquaGenie's skimming action. Pressure built up in the pressure chamber (behind the orifice plate) diverts some of this water through the tubing into the feeder tray. In the feeder tray a supply of chlorine is being constantly dissolved. Chlorine-laden water now pours over the tray's V-notch into the main sump of the AquaGenie, where it disinfects the water being drawn into the skimmer. Chemically treated water is then sent to the filter for removal of solids and is returned to the pool. If you desire to return the filtered water to the pool through an auxiliary return fitting, or through a jet nozzle installed on optional stairs, it's important to maintain water flow to the AquaGenie. If the pool is equipped with such an auxiliary return, there should be a valve on the return line to the AquaGenie, and another valve on the line to the auxiliary return fitting. When using the auxiliary return line, don't close the valve on the AquaGenie return line. Keep it "cracked open" enough to continue a flow of water to the AquaGenie. Enough back pressure will develop to keep the feeder operating. As long as water is leaving the feeder tray over the V-notch, it is being chlorinated and returned to the circulatory system. For full benefit of AquaGenie's automatic skimming and chlorinating, do not use auxiliary returns unnecessarily. Keep AquaGenie operating normally, with full flow as continuously as possible.

AquaGenie Canister

Carefully read directions and cautions on AquaGenie canister. Insert canister in feeder tray with canister cap being near the outside wall of the feeder tray. To prevent the possibility of a highly concentrated chlorine solution remaining in the feeder or entering the pool, the feeder tray will receive no water from pressure chamber and will automatically drain if the filter pump is shut down or if there is a power failure.

Never put any material in the feeder tray other than AquaGenie canisters and Trichloro tablets. Contact with other brands of chlorine tablets may cause a violent reaction or explosion

Adjusting Chlorine Levels

Start with an initial setting of 5 (five) on the chlorinator adjustment valve. Check your chlorine level and adjust to the desired level. 1 is the lowest setting with 10 being the highest. (see Sketch #1). When replacing cartridge turn to lowest setting before removing.

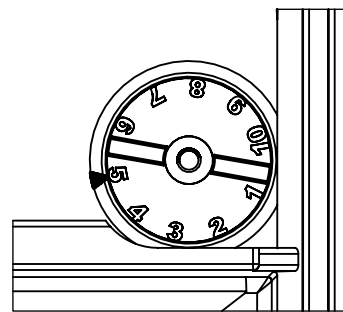

Sketch #1

Maintenance

Always maintain water level of pool up to the water level marks on the AquaGenie face plate (see Sketch #2). Flow should be over the weir. Always bring water level up to marks as soon as possible.

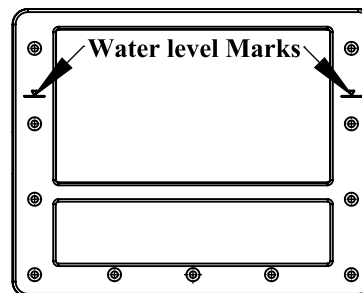

Vacuuming

1. Clean baskets before vacuuming. Backwash filter before and during the procedure, if the condition of the filter bed hampers flow.

2. Screw a plastic insert fitting in the vacuum adapter plate (5). Fill vacuum hose with water, attach hose to fitting and drop adapter plate over basket (or simply insert vacuum hose in adapter plate).

The adapter plate is tapered to seal against the seat in the **AquaGenie's** main sump.

3. Debris vacuumed off the bottom will be caught in the basket. Some material (hair and grass, for example) may pass through to the pump strainer. Finer material will be caught in the filter.

INSTALLATION INSTRUCTIONS

INSTALLATION INSTRUCTIONS

Read Completely Before Starting Installation. Refer to exploded view and parts list for proper nomenclature.

LOCATIONS OF AQUAGENIE

AquaGenie should be located near the center of a long side of the pool. Vary the location to orient the **AquaGenie's** mouth towards the prevailing winds as with ordinary skimmers. The action of **AquaGenie** will be effective as long as it is installed at least eight (8) feet from either end. Choosing the correct location is important, but is not as critical as with ordinary skimmers. (see sketch #3)

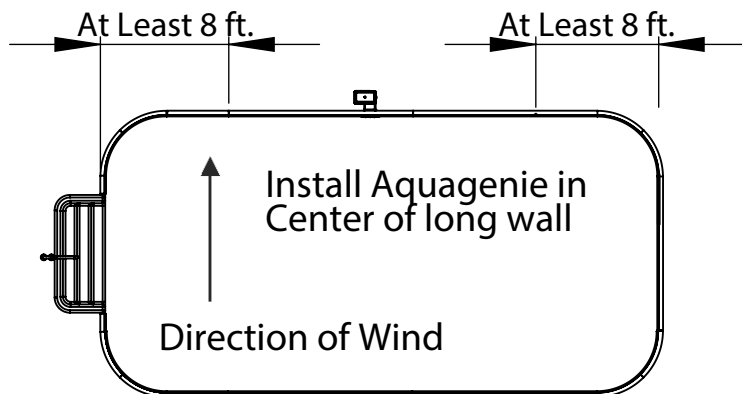

Sketch #3

PIPE ADAPTERS

Insert pipe adapters into the pressure throat port and the bottom port of the **AquaGenie**. Use the proper sealant (Permatex #51 Pipe Joint Compound or equal) for threaded connections and **POOLTITE** without primer 30 second minimum snug hold for rigid pipe connections. (See sketch #4).

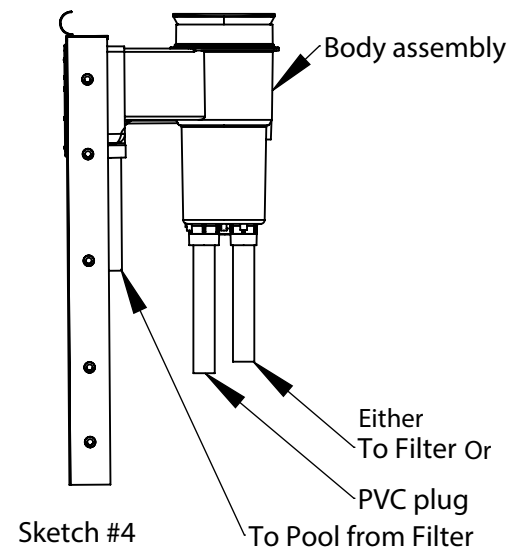

Sketch #4

AQUAGENIE INSTALLATION ON FOAM WALL PANELS

Foam wall panels are designed with embossed area for **AquaGenie** mounting location. Drill holes (3/8" dia.) at each inside corner of large embossed area from the back of panel. Make cutout by using a straight edge on front of panel to connect the holes. (See Sketch # 5). Using a jig saw, cut from face of panel to remove the shaded area shown in the sketch. Place **AquaGenie** in cutout and use holes as a template, mark holes. Using a 3/32" drill bit, drill pilot holes at marked holes. Holes should not be drilled all the way through but a maximum of 1/2" deep. Place **AquaGenie** in cutout and mount from back with (8) #10 x 3/4 hex washer head type AB screws. (See Sketch # 5)

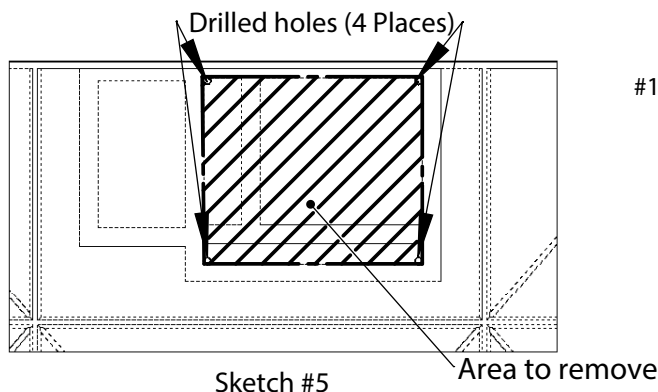

Sketch #5

CUTTING NOTE

The best results will be obtained by using a jig saw with 8 T.P.I. (fast cut, medium finish) blade. If jig saw is not available, use keyhole saw with 8-10 tooth combination blade. To prevent material buildup on saw blade, a cutting lubricant (water) should be used.

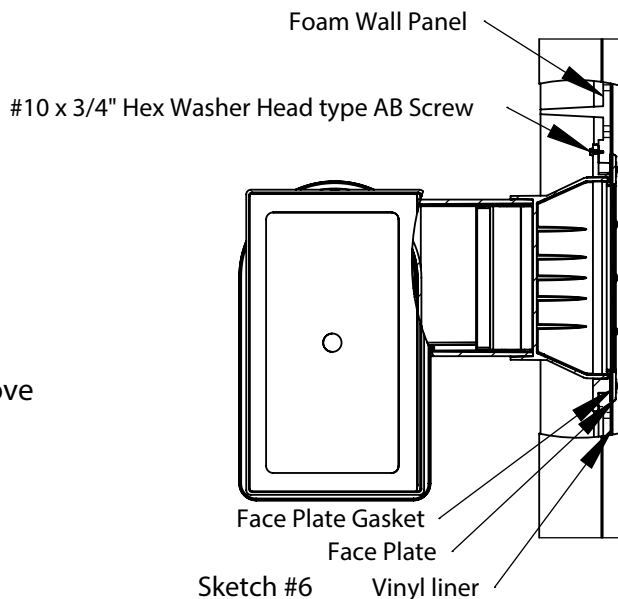

Sketch #6

STEEL PANEL POOLS WITH FACTORY CUT OUT

Insert screws (part #H006636) through the wall from the inside of the pool. Place steel shim (part #H01556SW) on back of wall on screws (if needed), then line up the AquaGenie mounting holes with the screws. Use washer and nut to secure. AquaGenie face will go through the wall for gasket placement before liner is installed.

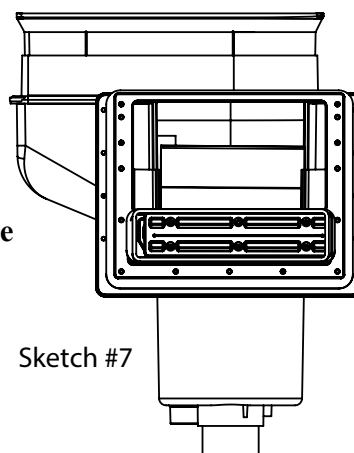

Sketch #7

BLOCKING UP

It is recommended to support the AquaGenie with a piece of 1-1/2" pvc pipe in the proper receptacle, located in the bottom of the unit, and support on a level concrete block. **Do not** disturb the AquaGenie while providing this support. Shim until the pier bears the weight of the AquaGenie.

PIPING

Use as few elbows as possible in the piping of the entire recirculation system. Each elbow reduces the efficiency of the AquaGenie in particular and the entire filtration system in general. Be sure to double clamp the return line when it connects to the adapter in the pressure throat. Follow piping layout as closely as possible. (See Sketch #7)

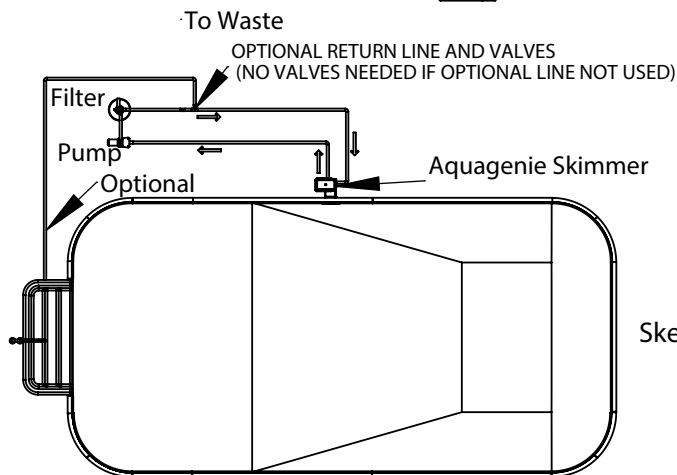

Sketch #8

OPTIONAL OVERFLOW

Remove knockout from bottom of skimmer body. Glue in a 1" x 5- 13/16" PVC pipe. (See Sketch #9)

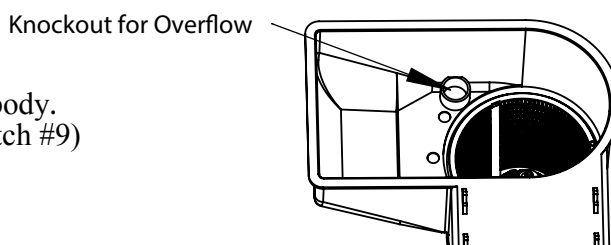

Sketch #9

INSTALLING FACE PLATE

Apply a small amount of sealant to one side of one of the large gaskets (#2) to hold it temporarily while assembling. Place the adhesive side of the gasket on the face plate, aligning the holes. (see sketch #10) Before positioning the face plate assembly, make two small vertical slits in the vinyl liner as indicated on sketch #11. The purpose of these slits is to permit easier removal of the vinyl from behind the horizontal bar of the face plate after installation of **AquaGenie**. Carefully position the face plate/gasket assembly on the vinyl liner, covering the face of the **AquaGenie**. Pierce the liner through the top two holes of the face plate prior to inserting screws. Screw two Phillips head Hi-Lo screws into these holes using only a #3 Phillips screwdriver bit. Using any other size screwdriver bit will damage the screw head and prevent making a leak-proof seal. **DO NOT** completely tighten the two screws at this time. Allow the heads to project about $\frac{1}{8}$ " from the countersink in the face plate. Now pierce the remaining holes through the face plate, and tighten screws to within $\frac{1}{8}$ " of countersink. Relieve tension on the vinyl liner *inside* the face plate by making crosswise slits in the vinyl as shown in sketch #12. At this point you may tighten all screws completely. (Uneven pressure may distort the face plate and cause uneven seating of gasket seal.) Excessive torque may break the corrosion-resistant screws. After the face plate has been installed, carefully cut out the vinyl liner using a sharp knife. Cut the top edge and the two sides of the skimmer opening, and the top, bottom and two sides of the orifice opening. Grasp the triangular piece of vinyl remaining at the bottom of the skimmer opening to remove it. The vinyl from behind the horizontal bar will be removed at this time. (See Sketch #13)

Only assemble the orifice plate after all piping is completed and flushed.

ASSEMBLY OF ORIFICE PLATE

Apply a small amount of Permatex to the back of the orifice plate. Place a small gasket on the top, as marked, being certain all holes are aligned, and all edges are aligned. Before mounting the orifice plate to the **AquaGenie**, make sure that when assembled, the nozzle slot slopes downward. (See Sketch #14 on next page)

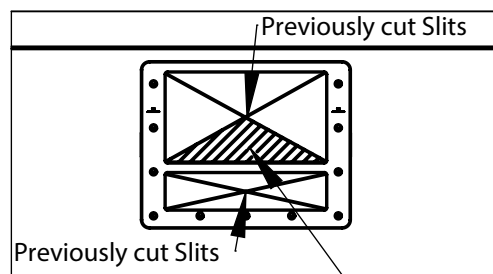
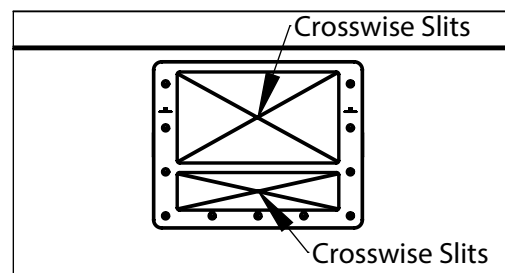
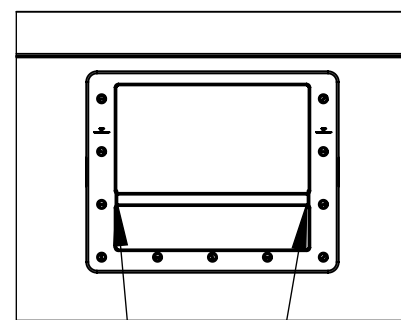
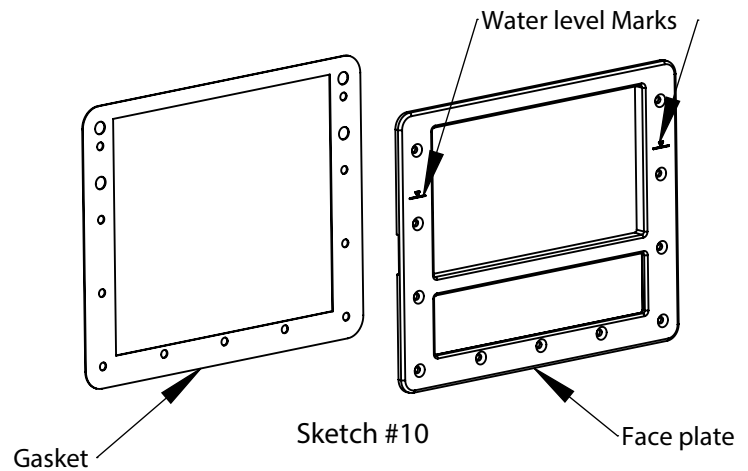

Pull up and out after cutting to remove triangular vinyl from behind horizontal bar.

Secure the assembly using six Hi-Lo screws. Again, use only a #3 Phillips screw driver. Tighten the screws evenly in the order shown on Sketch #15. Develop your final screw pressure by following this sequence 3 or 4 times, similar to the technique of tightening an engine head. The orifice plate is not designed to fit flush with the face plate. The amount of protrusion will vary with the type of pool wall (foam, steel, or wood). Do not over tighten! A torque of 20"-1 lb. maximum is permitted. Excessive torque may break the corrosion-resistant screws

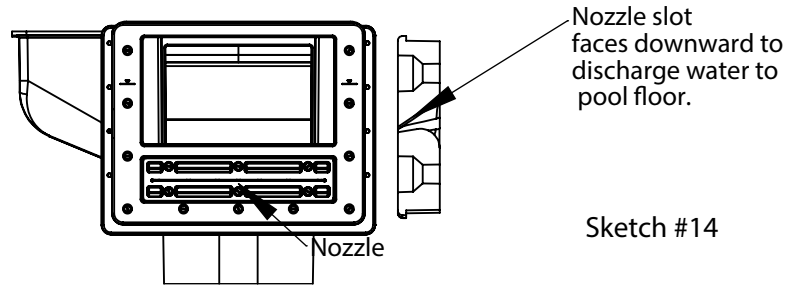

Sketch #14

BACKFILL

All backfill around the feeder must be free draining coarse sand or fine gravel. It should be very carefully tamped into place with an implement such as a shovel handle in layers to give maximum support.

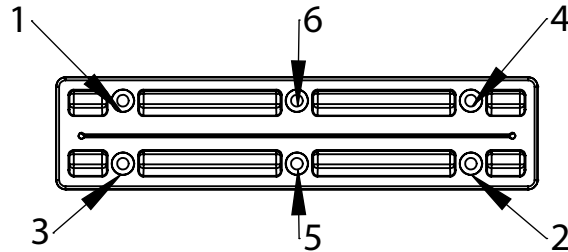

Sketch #15

THE INFORMATION CONTAINED IN THIS DOCUMENT IS THE SOLE PROPERTY OF HYDRA POOLS, A DIVISION OF PI, INC. ANY REPRODUCTION IN PART OR WHOLE WITHOUT WITH WRITTEN PERMISSION OF HYDRA POOLS A DIVISION OF PI, INC. IS PROHIBITED.

AQUAGENIE BILL OF MATERIALS

Item #	Part #	Description	# Required
1	HG110	ORFICE PLATE	1
2	HO2190	ORFICE PLATE GASKET	1
3	H00635	SCREW SET	1
4	HG105	FACE PLATE	1
5	HO1616	FACE PLATE GASKETS	2
6	HG150	WEIR ASSEMBLY	1
7	HG130P	BASKET (INCLUDES HANDLE)	1
8	H01691	SS FEEDER TUBE (WITH ORING)	1
9	HG115N	VACUUM ADAPTOR	1
10	HG140	EXTENSION COLLAR	1
11	HG120	COLLAR FEEDER	1
12	HG155	VALVE ASSEMBLY (WITH HOSES AND O RINGS)	1
13	HG145	CARTRIDGE ASSEMBLY (WITH CAP AND LABEL)	1
14	H01664	CARTRIDGE CAP ONLY	1
15	HG125	COVER	1

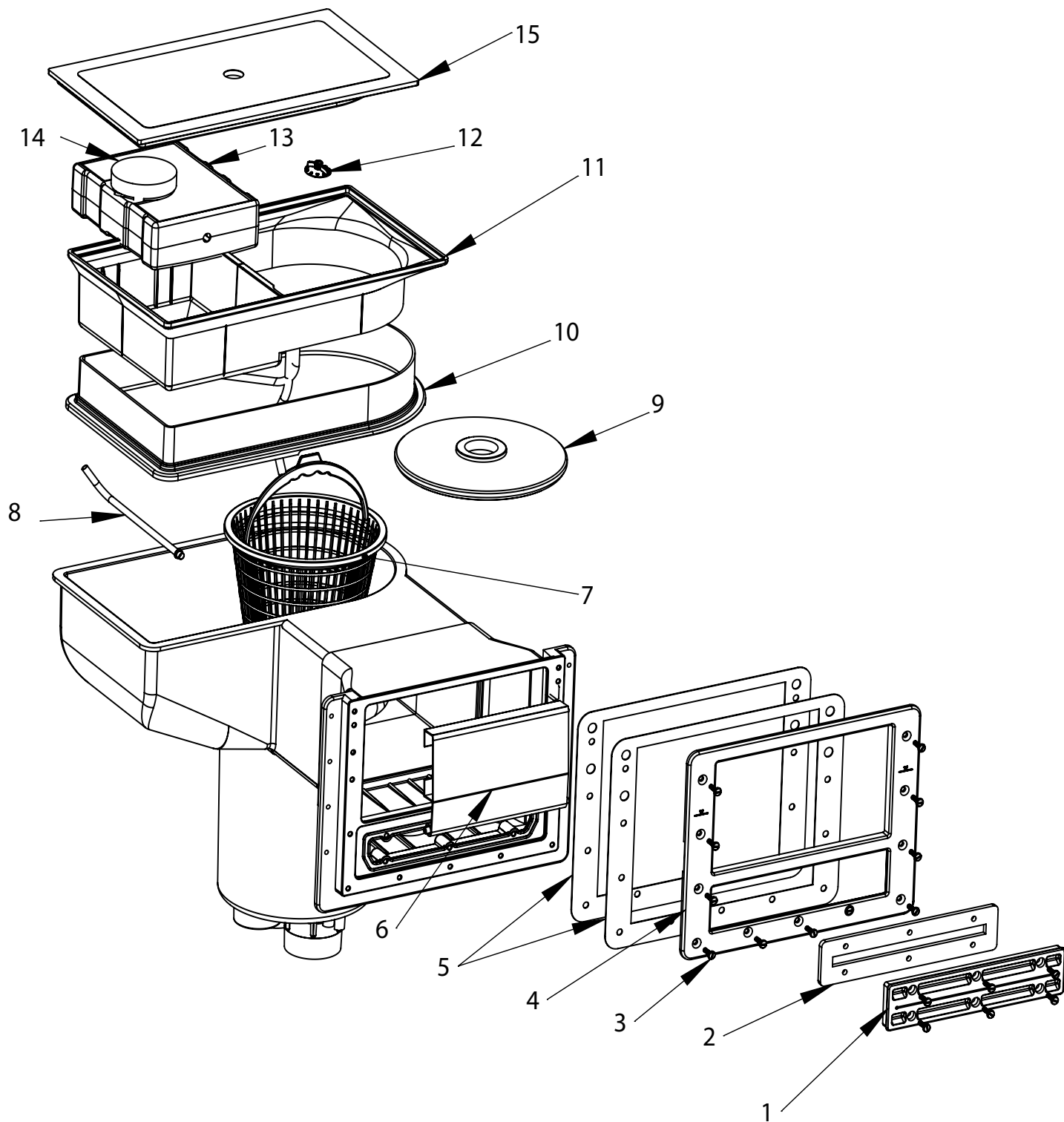

For replacement parts see your Dealer or visit www.aquagenie.com

Winterizing

We recommend using the patented *AquaGenie* Winter Cover, to order ask for part # H03116N to order go to aquagenie.com

Installing Winter Cover Gasket

To install gasket

1. Start at the top center of the gasket channel (See Sketch#1)
2. Gasket is installed with narrow side of the gasket installed in channel (See Sketch #2)
2. Work gasket into channel making sure is well seated.

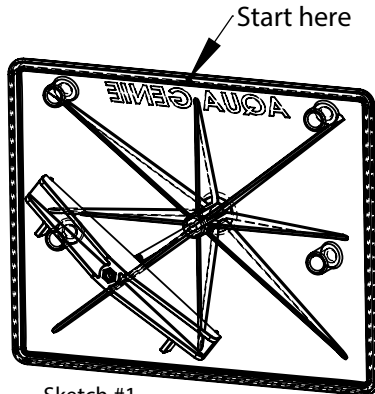

Sketch #1

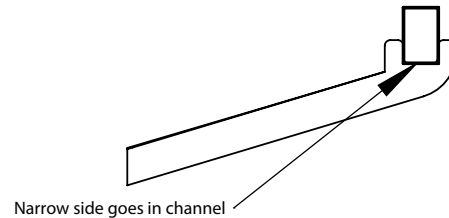

Sketch #2

Assemble Winter Cover

1. Place threaded rod through hole in winter cover ,assemble in the correct order. (See Sketch#3)

Note: O-Ring goes between Knob and cover.

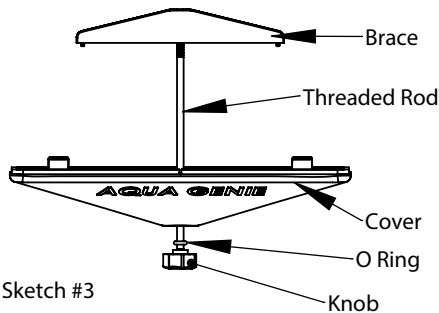

Sketch #3

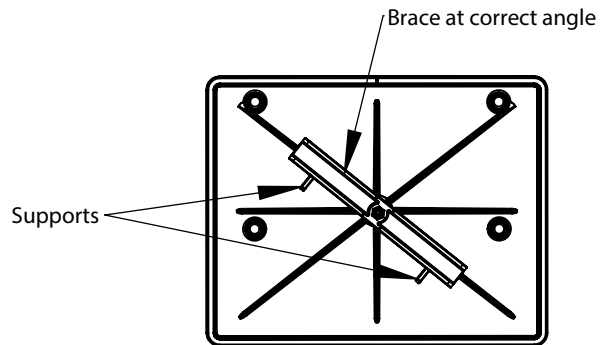

Sketch #4

Installing Winter Cover

1. Remove *AquaGenie* Cover to gain access for installation. (See Sketch #5)
2. Orient brace from top to bottom corner of cover ,with supports facing down. (See Sketch #4)
3. Guide the assembled Winter Cover through Weir opening (you do not have to remove weir assembly) (See Sketch #5). Brace goes behind lip in pressure throat.
4. Hold the cover against the faceplate with one hand and rotate the brace until it is horizontal.
5. Turn knob by hand until gaskets seats on faceplate. Brace will tighten against lip on pressure throat. (See Sketch#6) (Caution: over tightening will distort the gasket)
6. Drain water in basket well and follow pump and filter manufacturer's winterizing recommendations.

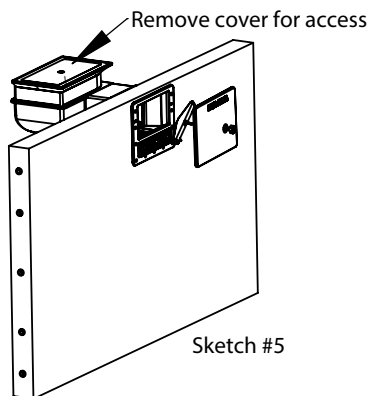

Sketch #5

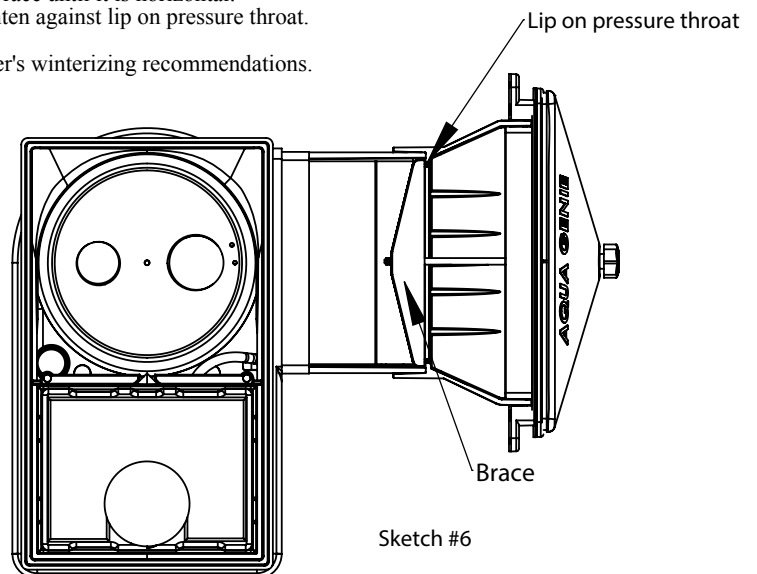

Sketch #6



INSTALLATION GUIDE

Installing a Rectangular Cover

IN-GROUND COVER INSTALLATION INSTRUCTIONS

1. Remove all ladders and handrails
2. Measure the pool and the cover. This will determine the overlap of the cover. Take the difference on width and length and divide by two. The overlap can vary from 10 to 15 inches.
3. Place cover over the pool carefully so you do not snag or damage the cover. The cautionary label should be facing up. Adjust to the overlap determined in step 1. Use something on the straps to hold the cover in place (buckets of water or bags of sand).
4. Mark the anchor points at the center of each wall. They are located 18 inches from the edge of the cover. Install the anchors. (See anchor section)
5. Attach straps to the springs, then place the springs on the anchors
6. Continue with the anchor points for the rest of the cover. With all anchors and springs installed, recheck all the anchors and straps to make sure they are secured and adjusted with equal tension.

Installing a Freeform Cover

IN-GROUND COVER INSTALLATION INSTRUCTIONS

1. Remove all ladders and handrails
2. Measure the pool and the cover. This will determine the overlap of the cover. Take the difference on width and length and divide by two. The overlap can vary from 10 to 15 inches.
3. Place cover over the pool carefully so you do not snag or damage the cover. The cautionary label should be facing up. Adjust to the overlap determined in step 1. Use something on the straps to hold the cover in place (buckets of water or bags of sand).
4. Mark the anchor points as shown below. They are located 18 inches from the edge of the cover. Install the anchors. (See anchor section)
5. Attach straps to the springs, then place the springs on the anchors
6. Continue with the anchor points for the rest of the cover. With all anchors and springs installed, recheck all the anchors and straps to make sure they are secured and adjusted with equal tension.

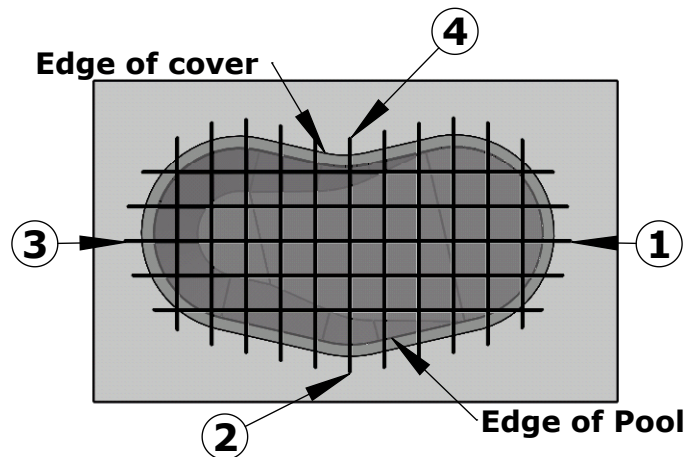
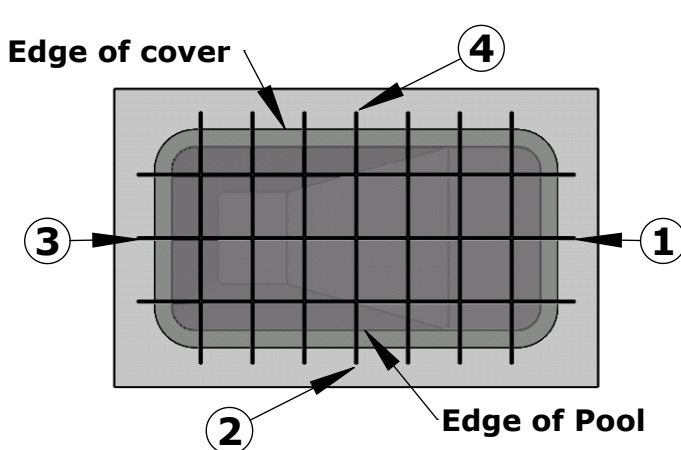

Included Hardware

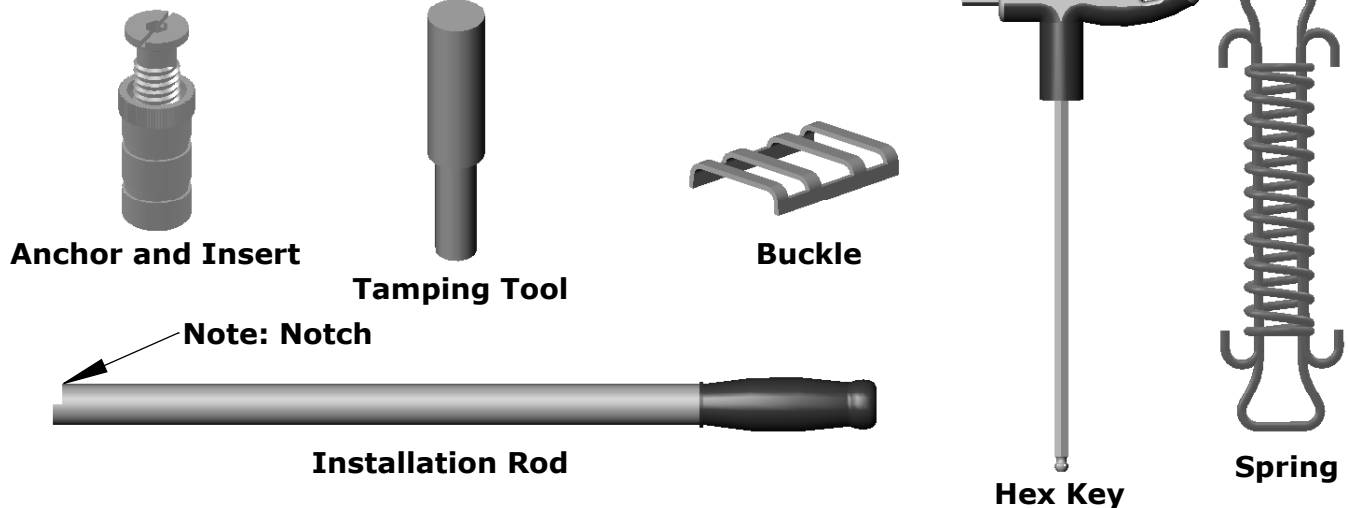

Anchor Layout

After the cover has the initial anchors, layout the remaining straps (18" from edge of cover). On rectangles you can use a chalk line to make sure the anchors are in a straight line.

Anchor Installation

Tools needed:

- Rotary Hammer Drill
- 3/4" Concrete Bit
- Chalk Line
- Hammer
- Goggles/protective Eyewear

WARNING: Always wear goggles or other appropriate eye protection while installing anchors or other pool equipment using power tools.

Concrete Decks

1. Drill about 2-1/4" inches into the deck using a rotary hammer drill with a 3/4 inch masonry bit. Vacuum or flush out the concrete dust in the bottom of the hole.
2. Remove the anchor insert from the anchor. Place the brass anchor into the hole and tamp it down carefully until flush with the deck using the tamping tool. Do not drive the anchor in with the anchor insert in place.
3. Screw the anchor insert into the anchor with the hex key, with around 1/3 of the anchor insert above the deck to secure the spring.

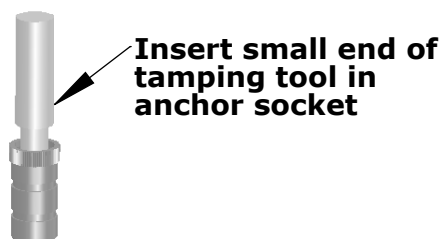

Other Deck Surfaces

1. For Brick, Pavers, Stone (or for wood decks less than 1-5/8") to be installed, you will need a 3/4" I.D. conduit or pipe that is 15" in length. Drill into the deck using a rotary hammer drill with an appropriate size masonry bit. Vacuum or flush out the concrete dust in the bottom of the hole.
2. Remove the brass insert from the anchor. Place the brass anchor into the pipe and drive the pipe into the hole and tamp it down carefully until flush with the deck using a block of wood. Do not drive the anchor in with the anchor insert in place.
3. Screw the brass insert into the casing with the hex key, with around 1/3 of the anchor insert above the deck to secure the spring.

Spring Installation

Spring to Strap Attachment

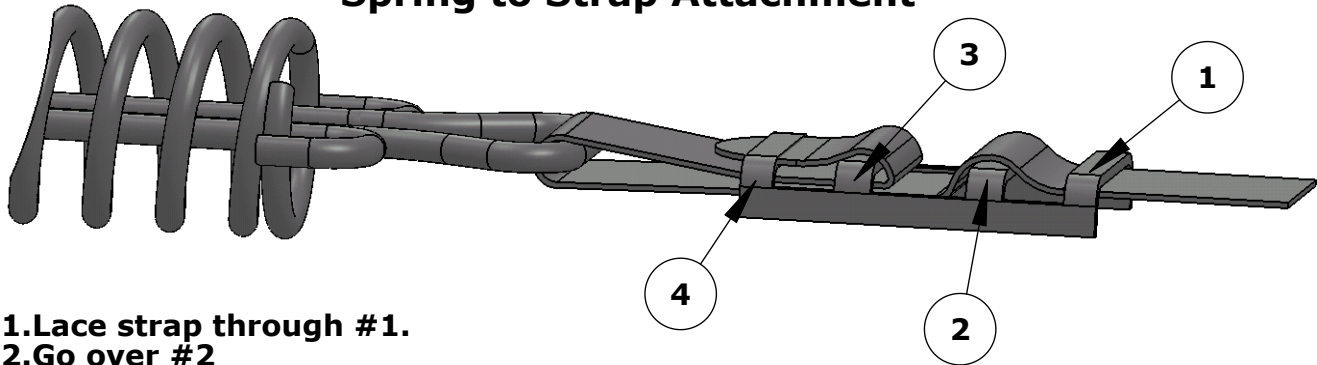

1. Lace strap through #1.
2. Go over #2
3. Between #2 and #3
4. Loop around square end of spring.
5. Back between #2 and #3
6. Push end underneath #4.

Installing Springs on the Anchors

1. Place the installation rod through the round end of the spring with notch in rod facing away from cover.
2. Place the end of rod over the anchor insert.
3. Pivot the rod away from the edge of the cover until the spring slides over the anchor insert.
4. Rotate the installation rod until the rod is free.

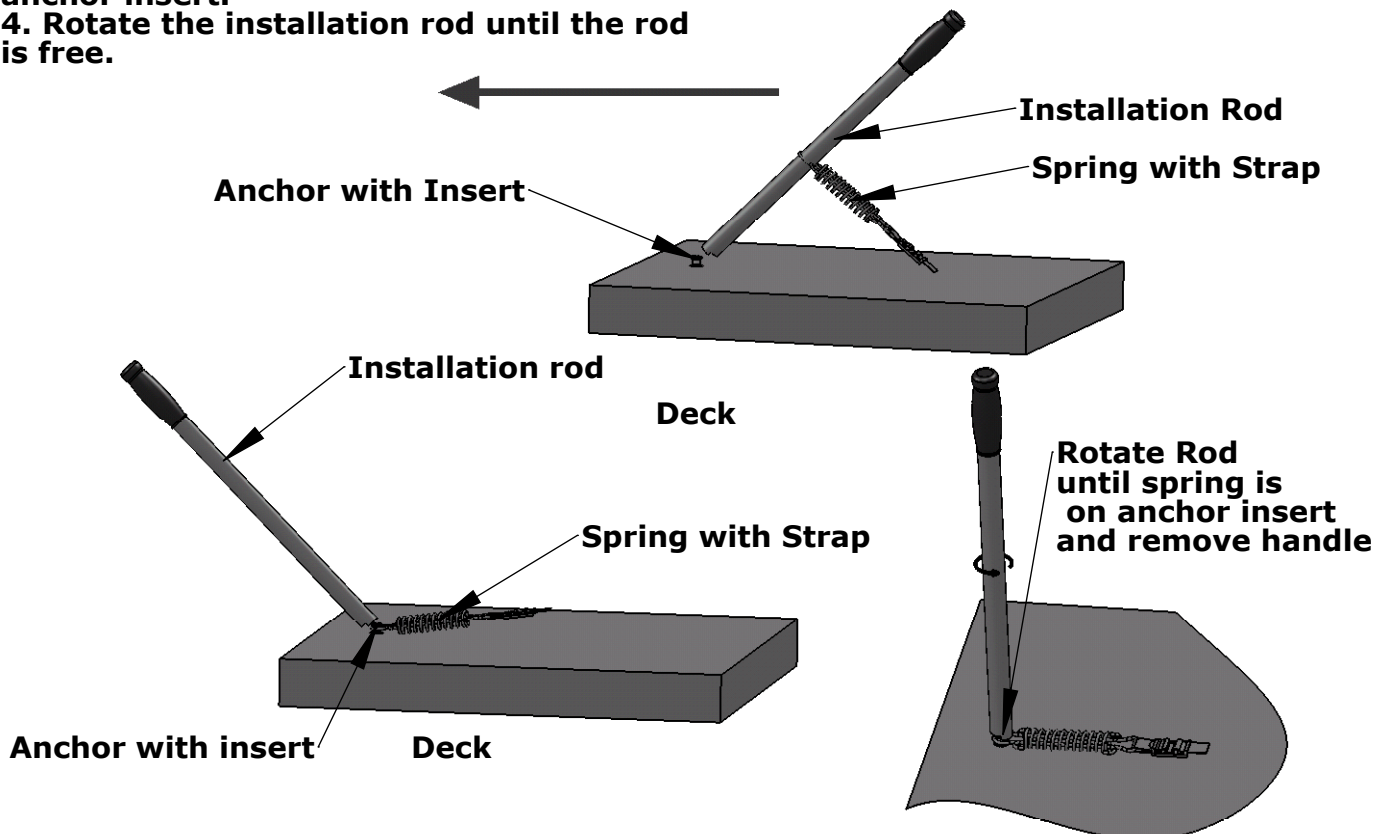

Spring Adjustment

1. The springs should be compressed 50%
 - 2 After initial installation recheck the spring tension to make sure it is correct the cover should fit tightly.
- A loose cover can sag and become damaged.*

Removing the Cover

- 1 Place the installation rod over the spring where it connects to the anchor. Make sure the notch is facing away from the cover
2. Rotate the installation rod until the spring is over the end of the installation rod.
3. Pull the rod toward the cover so the spring slides up the rod and relieves tension.
4. Using the Hex Key provided rotate the anchor insert until it is flush with the insert.

Insert handle into spring and rotate

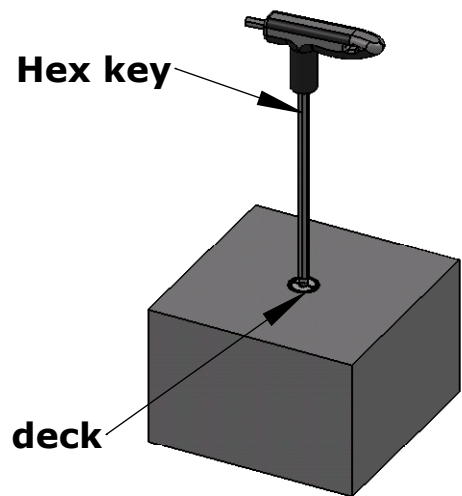
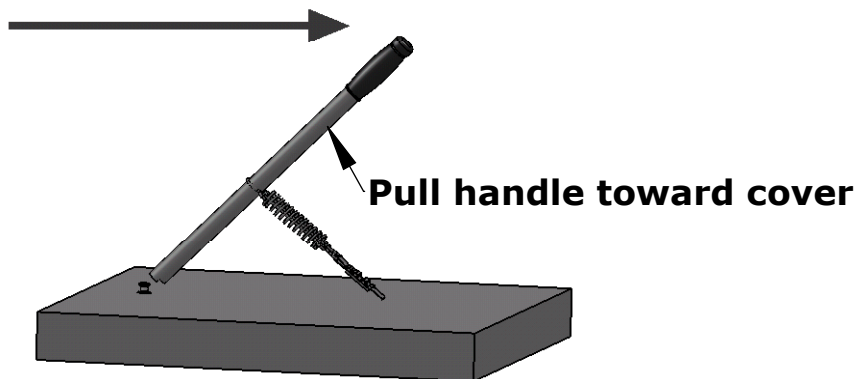
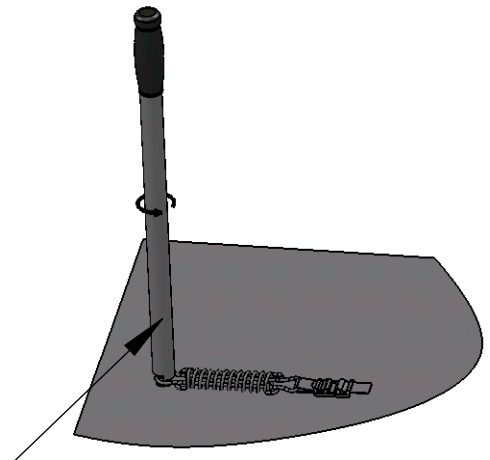

Maintaining Anchors

For smooth operation of the anchor inserts it is a good practice each spring and fall that they be flushed out to remove any dirt. The brass inserts may also be lightly sprayed with a silicone or Teflon lubricant to ensure smooth operation. Do not use any oil or grease!

Storing The Cover

When the cover is removed it should be cleaned of debris, allowed to dry, folded and placed in its storage bag. Store the cover in a dry area away from rodents.

Caring For Your Cover

- 1. Make sure the pools water level is never allowed to fall below 18" from the main deck level. Allowing a low water level will result in cover and/or spring damage during periods of snow accumulation. This type damage will not be covered under the warranty.**
- 2. Do not walk on the cover unless their is an emergency situation. It should not be jumped upon like a trampoline. Walking or jumping on the cover could result in damage not covered by the warranty**
- 3. Proper chemical treatment is necessary when closing the pool for the winter. The chemical levels should be checked in the spring, adjust as necessary.**
- 4. Strips to protect against abrasion are sewn to the cover to protect against normal coping wear.**
- 5. It is up to the installer to, when necessary, add protective padding to sharp corners or very rough areas of the pool.**
- 6. The cover should be stored in its storage bag when not installed. Any leaves and debris should be cleaned from the cover before storing.**
- 7. The cover should be stored in an area free of rodents.**
- 8. Never swim in the pool with the cover when it is partially installed.**
- 9. Check the cover periodically to be sure the cover is secured tightly on the pool. Adjust the straps to achieve the proper tension.**
- 10. Do not to drag the cover on decking or over the cover springs. Tears resulting from mishandling will not be covered under the warranty.**

Warranty

Hydra Covers warrants that the pool cover fabric will be free from defects in materials and workmanship during the Limited Warranty coverage period.

Hydra Covers will repair or replace, at Hydra Covers choice, the pool cover at no charge at any time during the first twelve months of the Limited Warranty coverage period. After the first twelve months of the Limited Warranty coverage period, At Hydra Covers choice will either, repair the pool cover, or give an allowance towards the replacement of the pool cover. The amount of the allowance will be determined by dividing the number of months remaining in the Limited Warranty coverage period by the total warranty period, and multiplying that percentage times the current dealer price. The warranty period is for 12 years.

The Warranty DOES NOT cover:

- 1. Replacement of hardware.**
- 2. Damage at the coping edge caused by wear or abrasion.**
- 3. Damages to the deck or surrounding surfaces of the pool.**
- 4. Damages caused by fire, vandalism, animals or insects, abuse and neglect, improper installation, acts of God, or use for any purpose other than covering a swimming pool.**
- 5. Deterioration from sun exposure.**
- 6. Damages caused by low water levels.**



HYDRA POOLS

BUILDING DREAMS SINCE 1984

Hydra Pools

www.hydrapools.com | Like us on **Facebook**

Rev. Level: A
Rev. Date: March 30, 2017
Document ID: QOP756 Polymer/Steel
Installation Manual

543 S. Main Street
Sweetwater, TN 37874
1.800.894.4876

21822 Hwy J46
Centerville, IA 54544
1.866.518.4181

710 West Farrell Street
Niota, TN 37826